



GRAVITATION

8.1 ▽ GRAVITATION AND GRAVITY

1. Distinguish between the terms gravitation and gravity. Give examples.

Gravitation. Every body in the universe attracts every other body with a force called force of gravitation. Thus

Gravitation is the force of attraction between any two bodies in the universe.

The attraction between the sun and earth, the attraction between a table and a chair lying in a room, etc., are examples of gravitation. Gravitation is the weakest of the four basic forces in nature. However, it is the most important force as it has played an important role in initiating the birth of stars and in controlling the structure and evolution of the entire universe.

Gravity. Gravity is a special case of gravitation. If one of the attracting bodies is the earth, then gravitation is called gravity.

Gravity is the force of attraction between the earth and any object lying on or near its surface.

A body thrown up falls back on the surface of the earth due to earth's force of gravity.

8.2 ▽ ACCELERATION DUE TO GRAVITY AND WEIGHT OF A BODY

2. What is meant by the term free fall ?

Free fall. The motion of a body under the influence of gravity alone is called a free fall. If we neglect the resistance or friction offered by air, the fall of a body in air is a free fall. In fact, a body falls freely only in vacuum. The motion of a small heavy body in air may be taken as a free fall because air resistance on it is very small.

3. What is meant by acceleration due to gravity ? Is it a scalar or a vector ?

Acceleration due to gravity. When a body falls freely towards the surface of the earth, its velocity continuously increases. The acceleration developed in its motion is called acceleration due to gravity.

The acceleration produced in a freely falling body under the gravitational pull of the earth is called acceleration due to gravity.

It is denoted by g . It is a vector having direction towards the centre of the earth. It does not depend on the mass, size and shape of the body. The value of g is constant at a given place. However, it varies from place to place on the surface of the earth. It depends on altitude, depth, rotation of the earth and shape of the earth.

Using lasers, it is possible to measure distances up to 10^{-9} m and by electronic devices time can be measured upto 10^{-9} s. Using these techniques, g can be determined to an accuracy of 1 part in 10^8 by observing the free fall of a body in vacuum.

Near the surface of the earth, $g = 9.8 \text{ ms}^{-2}$ or 32 ft s^{-2} .

4. What do you mean by weight of a body? Is it a scalar or vector? What are its units?

Weight of a body. The weight of a body is the measure of the gravitational pull exerted by the earth upon it.

Weight of a body is defined as the gravitational force with which a body is attracted towards the centre of the earth.

If the g is the acceleration due to gravity at a place, then a body of mass of m is attracted towards the centre of the earth with a force equal to mg at that place. Hence weight of a body is given by

$$W = mg$$

In vector notation, $\vec{W} = m\vec{g}$

Weight is a vector quantity. It is measured in the units of force such as newton, kgwt, etc. As the value of g varies from place to place, the weight of a body also varies from place to place.

8.3 NEWTON'S UNIVERSAL LAW OF GRAVITATION

5. How did Newton discover the universal law of gravitation?

Discovery of Newton's law of gravitation. One day in the year 1665, seeing an apple falling from a tree, Newton was inspired to think about the law of gravitation. He thought that the force which attracts the apple towards the earth might be the same as the force attracting the moon towards the earth. By comparing the acceleration due to gravity on the earth with the acceleration required to keep the moon in orbit around the earth, Newton was able to deduce the law of gravitation as discussed below.

Newton assumed that the moon revolved around the earth in a circular orbit of radius $R (= 3.84 \times 10^8 \text{ m})$, as shown in Fig. 8.1.

Period of moon around the earth,

$$T = 27.3 \text{ days} = 27.3 \times 86,400 \text{ s}$$

Speed of the moon

$$v = \frac{\text{Circumference of orbit}}{\text{Orbital period}}$$

$$\begin{aligned} &= \frac{2\pi \times (3.84 \times 10^8 \text{ m})}{27.3 \times 86400 \text{ s}} \\ &= 1.02 \times 10^3 \text{ ms}^{-1} \end{aligned}$$

Centripetal acceleration of the moon,

$$\begin{aligned} a_c &= \frac{v^2}{R} = \frac{(1.02 \times 10^3)^2}{3.84 \times 10^8} \\ &= 2.72 \times 10^{-3} \text{ ms}^{-2} \end{aligned} \quad \dots(i)$$

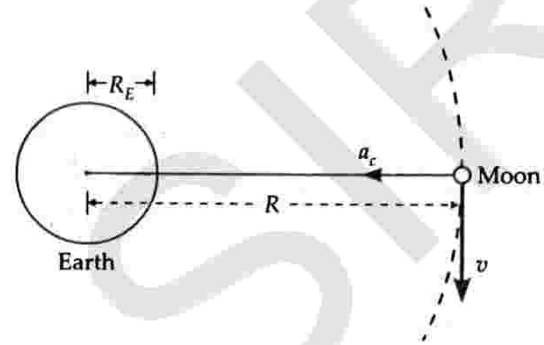

Fig. 8.1 Centripetal acceleration of the moon.

Acceleration due to gravity at the earth's surface, $g = 9.8 \text{ ms}^{-2}$.

Clearly $a_c \ll g$. Newton assumed that both acceleration of the moon and acceleration of the falling object are provided by earth's gravitational attraction. Newton argued that force and hence the acceleration produced must decrease with distance from the centre of the earth. From the relative values of a_c and g , he proposed that the gravitational force should be inversely proportional to the square of the distance. If R_E is the radius of the earth, then

$$\frac{a_c}{g} = \frac{1/R^2}{1/R_E^2} = \left(\frac{R_E}{R}\right)^2$$

Newton knew that $\frac{R_E}{R} = \frac{1}{60}$

$$\begin{aligned} \therefore a_c &= \left(\frac{R_E}{R}\right)^2 \times g = \left(\frac{1}{60}\right)^2 \times 9.8 \\ &= 2.72 \times 10^{-3} \text{ ms}^{-2}. \end{aligned}$$

This value is in close argument with the value obtained in equation (i), thus verifying the inverse square law. It is called *Newton's moon test*.

Newton further analysed that the force of gravitation exerted by an object should be proportional to its mass. By the third law of motion, the second object should exert an equal and opposite force on the first one. This force should be proportional to the mass of the second object. Taking into account all these facts, he arrived at his famous universal law of gravitation.

6. State Newton's law of gravitation. Hence define G . What are the units and dimensions of G ? Why is G called a universal gravitational constant?

Statement of Newton's law of gravitation. In 1687, Newton published the universal law of gravitation in his book *Principia*. This law can be stated as follows:

Every particle in the universe attracts every other particle with a force which is directly proportional to the product of their masses and inversely proportional to the square of the distance between them. This force acts along the line joining the two particles.

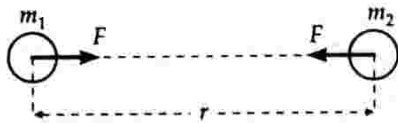

Fig. 8.2 Law of gravitation.

Consider two bodies of masses m_1 and m_2 and separated by distance r . According to the law of gravitation, the force of attraction F between them is such that

$$F \propto m_1 m_2 \quad \text{and} \quad F \propto \frac{1}{r^2}$$

$$\therefore F \propto \frac{m_1 m_2}{r^2}$$

or

$$F = G \frac{m_1 m_2}{r^2}$$

where G is a constant called *universal gravitational constant*.

Definition of G . If $m_1 = m_2 = 1$ and $r = 1$, then

$$F = G$$

The universal gravitational constant may be defined as the force of attraction between two bodies of unit mass each and placed unit distance apart.

In SI, the gravitational constant is equal to the force of attraction between two bodies of 1 kg each and placed 1 m apart.

In cgs system, the gravitational constant is equal to the force of attraction between two bodies of 1 g each and placed 1 cm apart.

Dimensions of G . As $F = G \frac{m_1 m_2}{r^2}$

$$\therefore G = \frac{Fr^2}{m_1 m_2}$$

$$\text{Dimensions of } G = \frac{MLT^{-2} \times L^2}{M \times M} = [M^{-1}L^3T^{-2}]$$

$$\text{Units of } G. \text{ As } G = \frac{Fr^2}{m_1 m_2}$$

$$\therefore \text{SI unit of } G = \frac{Nm^2}{kg \times kg} = Nm^2 kg^{-2}.$$

Similarly, cgs unit of $G = \text{dyn cm}^2 \text{g}^{-2}$.

Value of G . In SI, $G = 6.67 \times 10^{-11} Nm^2 kg^{-2}$

In cgs system, $G = 6.67 \times 10^{-8} \text{dyn cm}^2 \text{g}^{-2}$.

The value of G does not depend on the nature and size of the bodies. It also does not depend on the nature of the medium between the two bodies. That is why G is called universal gravitational constant.

7. Briefly explain the Cavendish's experiment for the determination of the universal constant G .

Cavendish's experiment for the determination of G . The value of the gravitational constant G was first determined experimentally by English scientist *Henry Cavendish* in 1798. The apparatus used is shown in Fig. 8.3.

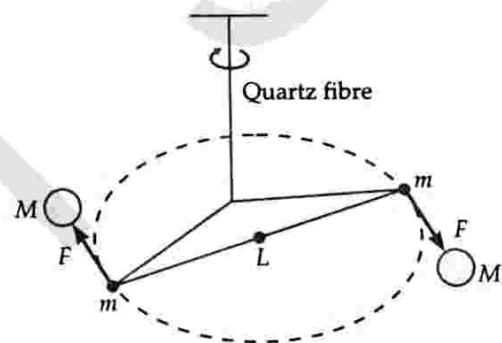

Fig. 8.3 Cavendish method.

Here two small identical spheres of lead, each of mass m are connected to the two ends of a light rod to form a dumb-bell. The rod is supported by a vertical length of quartz fibre. Two large lead spheres of mass M each are placed near the ends of the dumb-bell on the opposite sides in such a way that all the four spheres lie on a horizontal circle. The small spheres move towards the larger ones under the gravitational attraction,

$$F = \frac{GMm}{r^2}$$

where r is the distance between the centre of the large and its neighbouring small sphere.

The forces on the two small spheres form a couple which exerts a torque. This torque deflects the rod and twists the suspension till such time as the restoring torque of the fibre equals the deflecting gravitational torque. The angle of deflection θ is noted by measuring the deflection of a light beam by a lamp and scale arrangement. Let L be the length of the light rod.

Then,

$$\text{Deflecting torque} = F \times L = \frac{GMm}{r^2} L$$

$$\text{Restoring torque} = k\theta$$

where k is the restoring torque per unit angle of twist and is called *torsion constant* of the suspension fibre.

In rotational equilibrium, both the torques are equal and opposite.

$$\frac{GMm}{r^2} L = k\theta$$

$$\text{or} \quad G = \frac{k\theta r^2}{MmL}$$

Knowing all the quantities on the right hand side from the experiment, the value of G can be determined.

Since Cavendish's experiment, the measurement of G has been improved upon. The currently accepted value is

$$G = 6.67 \times 10^{-11} \text{ Nm}^2 \text{ kg}^{-2}.$$

8.4 ▽ EVIDENCES IN SUPPORT OF LAW OF GRAVITATION

8. Mention some experimental evidences in support of Newton's law of gravitation.

Experimental evidences in support of the law of gravitation. Many of the results predicted theoretically on the basis of the law of gravitation are found to be in close agreement with the experimental observations. Some of such evidences are as follows :

- The rotation of the earth around the sun or that of the moon around the earth is explained on the basis of this law.
- The tides are formed in oceans due to the gravitational force of attraction between the moon and sea-water.
- The times of solar and lunar eclipses calculated on the basis of the law of gravitation are found to be reasonably accurate.
- The orbits and periods of revolutions of artificial satellites can be predicted very accurately on the basis of this law.
- The value of g varies from place to place on the surface of the earth in accordance with the law of gravitation.

8.5 ▽ VECTOR FORM OF THE LAW OF GRAVITATION

9. Express law of gravitation in vector form. What are its implications ?

Vector form of Newton's Law of Gravitation. As shown in Fig. 8.4, consider two particles A and B of masses m_1 and m_2 and separated by distance r .

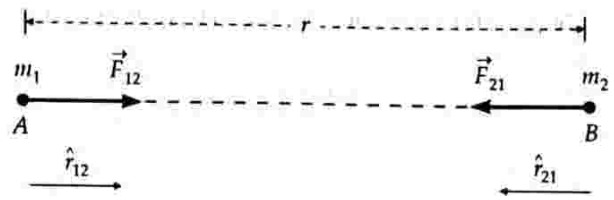

Fig. 8.4 Law of gravitation in vector form.

Let

$$\hat{r}_{12} = \text{a unit vector from } A \text{ to } B$$

$$\hat{r}_{21} = \text{a unit vector from } B \text{ to } A$$

$$\vec{F}_{12} = \text{gravitational force exerted on } A \text{ by } B$$

$$\vec{F}_{21} = \text{gravitational force exerted on } B \text{ by } A$$

In vector form, Newton's law of gravitation can be expressed as

$$\vec{F}_{12} = -G \frac{m_1 m_2}{r^2} \hat{r}_{21}$$

The negative sign shows that the direction of force \vec{F}_{12} is opposite to that of \hat{r}_{21} i.e., the gravitational force is attractive in nature so that m_1 is attracted towards m_2 .

$$\text{Similarly, } \vec{F}_{21} = -G \frac{m_1 m_2}{r^2} \hat{r}_{12}$$

$$\text{But } \hat{r}_{21} = -\hat{r}_{12}$$

$$\text{Hence } \vec{F}_{21} = -\vec{F}_{12}$$

Thus the vector form of the law of gravitation implies that the gravitational forces acting between two particles form *action and reaction pair*. As \vec{F}_{12} and \vec{F}_{21} are directed towards the centres of the two particles, so gravitational force is a *central force*.

8.6 ▽ IMPORTANT FEATURES OF GRAVITATIONAL FORCE

10. Mention the characteristic features of gravitational force.

Important features of gravitational force :

- The gravitational force between two masses is *independent of intervening medium*.
- The mutual gravitational forces between two bodies are equal and opposite i.e., they form *action and reaction pair*. Hence *gravitational forces obey Newton's third law of motion*.
- The law of gravitation strictly holds for *point masses*.

- (iv) The gravitational force between two point masses is a central force. Its magnitude depends only on r and has no angular dependence. Thus the gravitational force possesses *spherical symmetry*.
- (v) The gravitational force is a conservative force.
- (vi) The gravitational force between two bodies is independent of the presence of other bodies.

8.7 ▼ PRINCIPLE OF SUPERPOSITION OF GRAVITATIONAL FORCES

11. State and illustrate the principle of superposition of gravitational forces.

Principle of superposition of gravitational forces.

According to the principle of superposition, the gravitational force between two masses acts independently and uninfluenced by the presence of other bodies. Hence the resultant gravitational force acting on a particle due to a number of masses is the vector sum of the gravitational forces exerted by the individual masses on the given particle. Mathematically,

$$\vec{F}_R = \vec{F}_1 + \vec{F}_2 + \vec{F}_3 + \dots + \vec{F}_n = \sum_{i=1}^n \vec{F}_i$$

where $\vec{F}_1, \vec{F}_2, \vec{F}_3, \dots, \vec{F}_n$ are the gravitational forces exerted individually by n masses $m_1, m_2, m_3, \dots, m_n$ on the particle of mass m . Each force is determined by the law of gravitation.

Illustration. In Fig. 8.5, the total gravitational force on point mass m_1 is the vector sum of the gravitational forces exerted by the point masses m_2, m_3 and m_4 . According to the law of gravitation, the force on m_1 exerted by m_2 is

$$\vec{F}_{12} = -G \frac{m_2 m_1}{r_{21}^2} \hat{r}_{21}$$

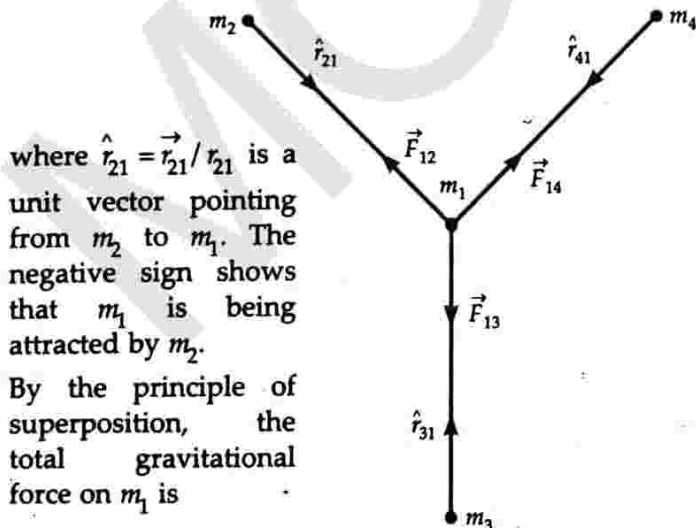

where $\hat{r}_{21} = \vec{r}_{21} / r_{21}$ is a unit vector pointing from m_2 to m_1 . The negative sign shows that m_1 is being attracted by m_2 .

By the principle of superposition, the total gravitational force on m_1 is

Fig. 8.5 Principle of superposition of gravitational forces.

$$\begin{aligned} \vec{F}_1 &= \vec{F}_{12} + \vec{F}_{13} + \vec{F}_{14} \\ &= -G \left[\frac{m_2 m_1}{r_{21}^2} \hat{r}_{21} + \frac{m_3 m_1}{r_{31}^2} \hat{r}_{31} + \frac{m_4 m_1}{r_{41}^2} \hat{r}_{41} \right] \end{aligned}$$

8.8 ▼ SHELL THEOREM

12. State Newton's shell theorem for the gravitational force.

Newton's shell theorem. This theorem gives gravitational force on a point mass due to a spherical shell or a solid sphere. It can be stated as follows :

- (i) If a point mass lies outside a uniform spherical shell/sphere with a spherically symmetric internal mass distribution, the shell/sphere attracts the point mass as if the entire mass of the shell/sphere were concentrated at its centre.

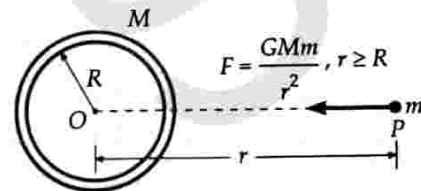

Fig. 8.6 Force on an outside particle due to a shell.

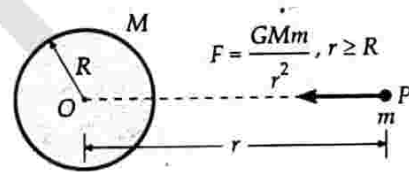

Fig. 8.7 Force on an outside particle due to a solid sphere.

- (ii) If a point mass lies inside a uniform spherical shell, the gravitational force on the point mass is zero. But if a point mass lies inside a homogeneous solid sphere, the force on the point mass acts towards the centre of the sphere. This force is exerted by the spherical mass situated interior to the point mass.

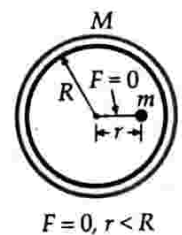

Fig. 8.8 No force acts on a particle inside a shell.

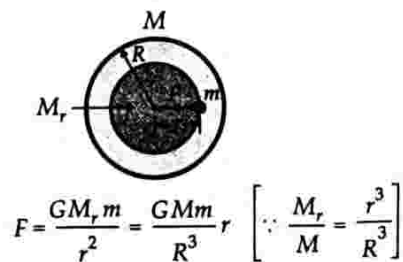

Fig. 8.9 A net force acts towards the centre on a particle inside ($r < R$) a solid sphere.

13. Is gravitational shielding possible ?

Gravitational shielding is not possible. Although the gravitational force on a particle inside a spherical shell is zero, yet the shell does not shield the other bodies outside it from exerting gravitational forces on the particle lying inside it. Thus gravitational shielding is not possible.



For Your Knowledge

- ▲ The law of gravitation is strictly true for point masses. However, it is valid in the following circumstances also :
 - ◆ For two bodies of any size provided they both have spherical symmetry.
 - ◆ When one body has spherical symmetry and the other is small compared with the separation between their centres.
 - ◆ When neither body has spherical symmetry but both are small compared with the separation between their centres.
- ▲ The value of G does not depend on the nature and size of the masses.
- ▲ The law of gravitation is universally valid. It applies to small objects on the earth, planets in the solar system and to galaxies.
- ▲ Though the gravitational force between two particles is central, the force between two finite rigid bodies is not necessarily along the line joining their centres of mass. For a particle lying outside a spherical symmetric body, the force acts as if the mass is concentrated at the centre of the body. Therefore, this force is central.
- ▲ The gravitational force on a particle lying inside a hollow body of any arbitrary shape is zero.

Examples based on

Newton's Law of Gravitation and Principle of Superposition

FORMULAE USED

1. Newton's law of gravitation, $F = \frac{G m_1 m_2}{r^2}$
2. Mass of planet or satellite, $M = \frac{4\pi^2 r^3}{GT^2}$
3. Principle of superposition of gravitational forces,

$$\vec{F}_R = \vec{F}_1 + \vec{F}_2 + \dots + \vec{F}_n$$

UNITS USED

Force of gravitation F is in newton, masses m_1, m_2 and M are in kg, distance r in metre and period of revolution in second.

CONSTANT USED

Universal gravitational constant,
 $G = 6.67 \times 10^{-11} \text{ Nm}^2 \text{ kg}^{-2}$.

EXAMPLE 1. Calculate the force of attraction between two balls each of mass 1 kg each, when their centres are 10 cm apart. Given $G = 6.67 \times 10^{-11} \text{ Nm}^2 \text{ kg}^{-2}$. [Delhi 1997]

Solution. Here $m_1 = m_2 = 1 \text{ kg}$, $r = 10 \text{ cm} = 0.10 \text{ m}$

$$\begin{aligned} \therefore F &= \frac{G m_1 m_2}{r^2} = \frac{6.67 \times 10^{-11} \times 1 \times 1}{(0.10)^2} \\ &= 6.67 \times 10^{-9} \text{ N.} \end{aligned}$$

EXAMPLE 2. The mass of planet Jupiter is $1.9 \times 10^{27} \text{ kg}$ and that of the sun is $1.99 \times 10^{30} \text{ kg}$. The mean distance of the Jupiter from the Sun is $7.8 \times 10^{11} \text{ m}$. Calculate the gravitational force which the sun exerts on Jupiter. Assuming that Jupiter moves in a circular orbit around the sun, calculate the speed of the Jupiter.

Solution. Here $M = 1.99 \times 10^{30} \text{ kg}$,

$$\begin{aligned} m &= 1.9 \times 10^{27} \text{ kg}, \quad r = 7.8 \times 10^{11} \text{ m}, \\ G &= 6.67 \times 10^{-11} \text{ Nm}^2 \text{ kg}^{-2} \end{aligned}$$

$$\begin{aligned} \therefore F &= \frac{GMm}{r^2} = \frac{6.67 \times 10^{-11} \times 1.99 \times 10^{30} \times 1.9 \times 10^{27}}{(7.8 \times 10^{11})^2} \\ &= 4.145 \times 10^{23} \text{ N.} \end{aligned}$$

The gravitational force of attraction due to the sun provides the necessary centripetal force to the Jupiter to move in the circular orbit. If v is the orbital speed of Jupiter, then

$$\frac{mv^2}{r} = F$$

$$\begin{aligned} \text{or} \quad v &= \sqrt{\frac{rF}{m}} = \sqrt{\frac{7.8 \times 10^{11} \times 4.145 \times 10^{23}}{1.9 \times 10^{27}}} \\ &= 1.304 \times 10^4 \text{ ms}^{-1}. \end{aligned}$$

EXAMPLE 3. Two particles, each of mass m , go round a circle of radius R under the action of their mutual gravitational attraction. Find the speed of each particle.

Solution. The force on each particle is directed along the radius of the circle. The two particles will always lie at the ends of a diameter so that distance between them is $2R$.

$$\therefore F = G \frac{m \times m}{(2R)^2} = \frac{Gm^2}{4R^2}$$

As this force provides the centripetal force, so

$$\frac{Gm^2}{4R^2} = \frac{mv^2}{R}$$

$$\text{or} \quad v = \sqrt{\frac{Gm}{4R}}$$

EXAMPLE 4. The mean orbital radius of the earth around the sun is $1.5 \times 10^8 \text{ km}$. Calculate the mass of the sun if $G = 6.67 \times 10^{-11} \text{ Nm}^2 \text{ kg}^{-2}$.

Solution. Here $r = 1.5 \times 10^8 \text{ km} = 1.5 \times 10^{11} \text{ m}$

$$T = 365 \text{ days} = 365 \times 24 \times 3600 \text{ s}$$

\therefore Centripetal force required = Force of gravitation between the earth and the sun

$$\therefore \frac{mv^2}{r} = \frac{GMm}{r^2} \quad \text{or} \quad \frac{m \left(\frac{2\pi r}{T} \right)^2}{r} = \frac{GMm}{r^2}$$

$$\begin{aligned} \text{or} \quad M &= \frac{4\pi^2 r^3}{GT^2} \\ &= \frac{4 \times 9.87 \times (1.5 \times 10^{11})^3}{6.67 \times 10^{-11} \times (365 \times 24 \times 3600)^2} \\ &= 2.01 \times 10^{30} \text{ kg.} \end{aligned}$$

EXAMPLE 5. A mass M is broken into two parts of masses m_1 and m_2 . How are m_1 and m_2 related so that force of gravitational attraction between the two parts is maximum?

Solution. Let $m_1 = m$, then $m_2 = M - m$.

Force of gravitation between the two parts when they are placed distance r apart is

$$F = G \frac{m(M-m)}{r^2} = \frac{G}{r^2} (Mm - m^2)$$

Differentiating w.r.t m , we get

$$\frac{dF}{dm} = \frac{G}{r^2} (M - 2m)$$

For F to be maximum, $\frac{dF}{dm} = 0$

$$\text{or} \quad \frac{G}{r^2} (M - 2m) = 0$$

$$\text{or} \quad M = 2m \quad \text{or} \quad m = M/2$$

$$\therefore m_1 = m_2 = M/2.$$

EXAMPLE 6. Three equal masses of $m \text{ kg}$ each are fixed at the vertices of an equilateral triangle ABC , as shown in Fig. 8.10.

(a) What is the force acting on a mass $2m$ placed at the centroid G of the triangle?

(b) What is the force if the mass at the vertex A is doubled?

Take $AG = BG = CG = 1 \text{ m}$

[NCERT, Delhi 06]

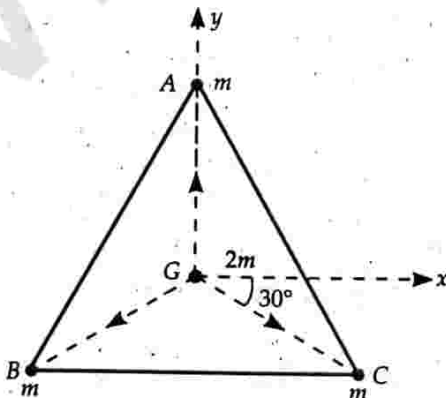

Fig. 8.10

Solution. We choose the co-ordinate axes as shown in Fig. 8.10.

Angle between GC and positive x -axis = 30° .

Angle between GB and negative x -axis = 30° .

Force on mass at G due to mass at A ,

$$\vec{F}_{GA} = \frac{Gm(2m)}{1^2} \hat{j}$$

Force on mass at G due to mass at B ,

$$\vec{F}_{GB} = \frac{Gm(2m)}{1^2} (-\hat{i} \cos 30^\circ - \hat{j} \sin 30^\circ)$$

Force on mass at G due to mass at C ,

$$\vec{F}_{GC} = \frac{Gm(2m)}{1^2} (+\hat{i} \cos 30^\circ - \hat{j} \sin 30^\circ)$$

By the principle of superposition, the resultant force on mass $2m$ is

$$\begin{aligned} \vec{F}_R &= \vec{F}_{GA} + \vec{F}_{GB} + \vec{F}_{GC} \\ &= 2Gm^2 [\hat{j} + (-\hat{i} \cos 30^\circ - \hat{j} \sin 30^\circ) \\ &\quad + (\hat{i} \cos 30^\circ - \hat{j} \sin 30^\circ)] \\ &= 2Gm^2 [\hat{j} - 2\hat{j} \sin 30^\circ] \\ &= 2Gm^2 (\hat{j} - \hat{j}) = 0. \end{aligned}$$

From symmetry consideration also, the resultant force on mass $2m = 0$.

(b) Now the mass at the vertex A is $2m$. Then

$$\vec{F}_{GA} = \frac{G(2m)(2m)}{1^2} \hat{j} = 4Gm^2 \hat{j}$$

\vec{F}_{GB} and \vec{F}_{GC} remain same as above.

$$\begin{aligned} \therefore \vec{F}_R &= \vec{F}_{GA} + \vec{F}_{GB} + \vec{F}_{GC} \\ &= 2Gm^2 [2\hat{j} + (-\hat{i} \cos 30^\circ - \hat{j} \sin 30^\circ) \\ &\quad + (\hat{i} \cos 30^\circ - \hat{j} \sin 30^\circ)] \\ &= 2Gm^2 [2\hat{j} - 2\hat{j} \sin 30^\circ] \\ &= 2Gm^2 (2\hat{j} - \hat{j}) = 2Gm^2 \hat{j}. \end{aligned}$$

✖ PROBLEMS FOR PRACTICE

1. A sphere of mass 40 kg is being attracted by another sphere of mass 80 kg with a force equal to $1/4$ of a milligram weight when their centres are 30 cm apart. Calculate the value of G .

$$(\text{Ans. } 6.88 \times 10^{-11} \text{ Nm}^2 \text{kg}^{-2})$$

2. The centres of two identical spheres are 1.0 m apart. If the gravitational force between the spheres be 1.0 N , then what is the mass of each sphere? ($G = 6.67 \times 10^{-11} \text{ m}^3 \text{kg}^{-1} \text{s}^{-2}$).

$$(\text{Ans. } 1.225 \times 10^5 \text{ kg})$$

3. Find the gravitational attraction between two H-atoms of a hydrogen molecule. Given $G = 6.67 \times 10^{-11} \text{ Nm}^2 \text{ kg}^{-2}$, mass of the atom $= 1.67 \times 10^{-27} \text{ kg}$ and distance between two H-atoms $= 1 \text{ \AA}$. (Ans. $1.86 \times 10^{-44} \text{ N}$)
4. Calculate the force of gravitation between two bodies, each of mass 100 kg and 1 m apart on the surface of the earth. Will the force of attraction be different if the same bodies are taken on the moon, their separation remaining constant? (Ans. $6.67 \times 10^{-7} \text{ N}$, No)
5. An apple of mass 0.25 kg falls from a tree. What is the acceleration of the apple towards the earth? Also calculate the acceleration of the earth towards the apple. Mass of the earth $= 5.983 \times 10^{24} \text{ kg}$, Radius of the earth $= 6.378 \times 10^6 \text{ m}$ and $G = 6.67 \times 10^{-11} \text{ Nm}^2 \text{ kg}^{-2}$. (Ans. 9.810 ms^{-2} , $4.099 \times 10^{-25} \text{ ms}^{-2}$)
6. If the mass of the sun is $2 \times 10^{30} \text{ kg}$, the distance of the earth from the sun is $1.5 \times 10^{11} \text{ m}$ and period of revolution of the earth around the sun is one year ($= 365.3 \text{ days}$), calculate the value of gravitational constant. (Ans. $6.69 \times 10^{-11} \text{ Nm}^2 \text{ kg}^{-2}$)
7. How far from earth must a body be along a line towards the sun so that the sun's gravitational pull on it balances that of the earth. Distance between sun and earth's centre is $1.5 \times 10^{10} \text{ km}$. Mass of sun is 3.24×10^5 times mass of earth. (Ans. $2.63 \times 10^7 \text{ km}$)

✕ HINTS

1. Here $m_1 = 80 \text{ kg}$, $m_2 = 40 \text{ kg}$, $r = 30 \text{ cm} = 0.30 \text{ m}$
- $$F = \frac{1}{4} \text{ mg wt} = \frac{1}{4} \times 10^{-6} \text{ kg wt}$$
- $$= \frac{10^{-6} \times 9.8}{4} \text{ N}$$
- $$G = \frac{Fr^2}{m_1 m_2} = \frac{10^{-6} \times 9.8 \times 0.30 \times 0.30}{4 \times 80 \times 40}$$
- $$= 6.88 \times 10^{-11} \text{ Nm}^2 \text{ kg}^{-2}$$
3. $F = G \frac{m_1 m_2}{r^2}$
- $$= \frac{6.67 \times 10^{-11} \times 1.67 \times 10^{-27} \times 1.67 \times 10^{-27}}{(10^{-10})^2}$$
- $$= 1.86 \times 10^{-44} \text{ N}$$
4. $F = \frac{Gm_1 m_2}{r^2} = \frac{6.67 \times 10^{-11} \times 100 \times 100}{(1)^2}$
- $$= 6.67 \times 10^{-7} \text{ N}$$

The force of attraction between the two bodies will remain same on the moon as the masses of two bodies also remain the same.

5. Here $m = 0.25 \text{ kg}$, $M = 5.983 \times 10^{24} \text{ kg}$,
 $R = 6.378 \times 10^6 \text{ m}$
 Force of gravitation between earth and apple,
 $F = \frac{GMm}{R^2}$

Acceleration of the apple towards the earth,
 $a = \frac{F}{m} = \frac{GM}{R^2}$

$$= \frac{6.67 \times 10^{-11} \times 5.983 \times 10^{24}}{(6.378 \times 10^6)^2} = 9.810 \text{ ms}^{-2}$$

Acceleration of the earth towards the apple,
 $a' = \frac{F}{m} = \frac{Gm}{R^2} = \frac{6.67 \times 10^{-11} \times 0.25}{(6.378 \times 10^6)^2}$

$$= 4.099 \times 10^{-25} \text{ ms}^{-2}$$

- 7: Let P be a point at distance x where the gravitational pull due to the earth and the sun balance. Then

$$\frac{GM_E m}{x^2} = \frac{GM_S m}{(r-x)^2}$$

or $\frac{(r-x)^2}{x^2} = \frac{M_S}{M_E} = 3.24 \times 10^5$

or $\frac{r-x}{x} = \sqrt{3.24 \times 10^5} = 570$

or $x = \frac{r}{571} = \frac{1.5 \times 10^{10}}{571} = 2.63 \times 10^7 \text{ km}$

8.9 ACCELERATION DUE TO GRAVITY OF THE EARTH

14. Write expressions for the gravitational force exerted by the earth on a point mass m located above, below and on the surface of the earth. Hence deduce expression for g on the earth's surface.

Acceleration due to gravity of the earth. Consider the earth to be a sphere of radius R and uniform density ρ . Then its mass will be

$$M = \frac{4}{3} \pi R^3 \rho$$

(i) **At points above the earth's surface.** Suppose a point mass m is situated outside the earth at a distance r from its centre. According to shell theorem, the gravitational force at a point outside the earth is just as if the entire mass of the earth is concentrated at its centre. Hence the gravitational force on the point mass m is

$$F = G \frac{Mm}{r^2} \quad (\text{For } r > R)$$

(ii) **At points below the earth's surface.** As shown in Fig. 8.11, suppose a point mass m is located at a point

P in a mine at a depth d below the earth's surface. Thus the point P lies outside the sphere of radius r and inside the shell of thickness

$$d = R - r.$$

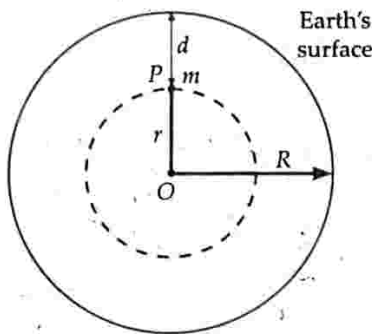

Fig. 8.11 Gravitational force on a mass m at depth d .

According to shell theorem, the outer shell exerts no force on the mass m kept at point P . The inner sphere of radius r exerts a force on point mass m at point P as if its mass m_r is concentrated at the centre. Thus the gravitational force on mass m is

$$F = \frac{Gmm_r}{r^2}$$

$$\text{But } m_r = \frac{4}{3} \pi r^3 \rho = \frac{4}{3} \pi R^3 \rho \frac{r^3}{R^3} = M \frac{r^3}{R^3}$$

$$F = \frac{Gm}{r^2} \cdot \frac{Mr^3}{R^3}$$

$$\text{or } F = \frac{GMm}{R^3} r \quad (\text{For } r < R)$$

(iii) **At points on the earth's surface.** If the point mass m is situated on the earth's surface, then $r = R$, and the gravitational force on mass m is

$$F = \frac{GMm}{R^3} \cdot R$$

$$\text{or } F = \frac{GMm}{R^2} \quad (\text{For } r = R)$$

Suppose the mass m experiences acceleration g , called the acceleration due to gravity, then according to Newton's second law of motion,

$$F = mg$$

$$mg = \frac{GMm}{R^2}$$

$$\text{or } g = \frac{GM}{R^2}$$

This gives the acceleration due to gravity on the surface of the earth.

15. Obtain an expression for the acceleration due to gravity g in terms of mass of the earth M and gravitational constant G .

Relation between g and G .

Consider the earth to be a sphere of mass M and radius R . Suppose a body of mass m is lying on its surface, as shown in Fig. 8.12. According to the law of gravitation, the force of attraction between the earth and the body is

$$F = \frac{GMm}{R^2}$$

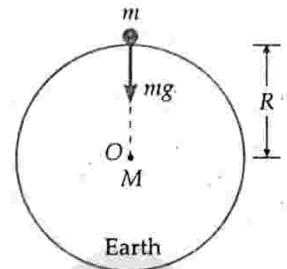

Fig. 8.12 Relation between g and G .

Here we have used shell theorem according to which the gravitational force due to a sphere on a mass outside it acts as if the entire mass of the sphere is concentrated at its centre. The force of gravity F produces an acceleration g (called acceleration due to gravity) in the body of mass m . From Newton's second law of motion, we get

$$F = mg$$

From the above two equations, we have

$$mg = \frac{GMm}{R^2} \quad \text{or} \quad g = \frac{GM}{R^2}$$

This gives acceleration due to gravity on the surface of the earth. The value of g is independent of the mass, size and shape of the body falling under gravity.

8.10 MASS AND DENSITY OF THE EARTH

16. Explain how the mass and average density of the earth can be estimated from the knowledge of G ?

Mass of the earth. As $g = \frac{GM}{R^2}$, therefore

$$\text{Mass of the earth, } M = \frac{gR^2}{G}$$

Knowing the values of g , G and R , the mass of the earth can be determined.

$$\text{As } g = 9.8 \text{ ms}^{-2}, \quad R = 6.37 \times 10^6 \text{ m,}$$

$$G = 6.67 \times 10^{-11} \text{ Nm}^2\text{kg}^{-2}$$

$$M = \frac{9.8 \times (6.37 \times 10^6)^2}{6.67 \times 10^{-11}}$$

$$= 5.97 \times 10^{24} \text{ kg} \approx 6 \times 10^{24} \text{ kg.}$$

As the value G was first experimentally determined by Cavendish, so he is regarded as the first person to have weighed the earth.

Average density of the earth. If the earth is taken as a sphere of radius R and average density ρ , then its mass would be

$$M = \text{Volume} \times \text{density} = \frac{4}{3} \pi R^3 \rho$$

But mass of the earth,

$$M = \frac{gR^2}{G}$$

$$\therefore \frac{4}{3} \pi R^3 \rho = \frac{gR^2}{G} \quad \text{or} \quad \rho = \frac{3g}{4\pi GR}$$

Knowing the values of g , G and R , the average density ρ of the earth can be estimated. Thus

$$\rho = \frac{3 \times 9.8}{4 \times 3.142 \times 6.67 \times 10^{-11} \times 6.37 \times 10^6}$$

$$= 5497 \text{ kg m}^{-3} \approx 5500 \text{ kg m}^{-3}.$$

In fact, the density of the upper layers of the earth is around 2700 kg m^{-3} while the density of the inner layer is much larger than average value of 5500 kg m^{-3} .

Examples based on Mass and Density of Earth

FORMULAE USED

1. Acceleration due to gravity on the earth's surface,

$$g = \frac{GM}{R^2}$$

2. Mass of the earth, $M = \frac{gR^2}{G}$

3. Mean density of earth, $\rho = \frac{3g}{4\pi GR}$

4. From Kepler's law of periods, $M = \frac{4\pi^2 r^3}{GT^2}$

5. Weight of a body, $W = mg$

UNITS USED

The masses M and m are in kg, acceleration due to gravity g in ms^{-2} , period of revolution T in second and density ρ in kg m^{-3} .

EXAMPLE 7. Weighing the Earth : You are given the following data : $g = 9.81 \text{ ms}^{-2}$, $R_E = 6.37 \times 10^6 \text{ m}$, the distance to the moon $r = 3.84 \times 10^8 \text{ m}$ and the time period of the moon's revolution is 27.3 days. Obtain the mass of the Earth M_E in two different ways. [NCERT]

Solution. (i) $M_E = \frac{gR_E^2}{G} = \frac{9.81 \times (6.37 \times 10^6)^2}{6.67 \times 10^{-11}}$

$$= 5.97 \times 10^{24} \text{ kg.}$$

- (ii) From Kepler's law of periods,

$$M_E = \frac{4\pi^2 r^3}{GT^2} = \frac{4 \times 3.14 \times 3.14 \times (3.84)^3 \times 10^{24}}{6.67 \times 10^{-11} \times (27.3 \times 24 \times 60 \times 60)^2}$$

$$= 6.02 \times 10^{24} \text{ kg.}$$

Both the methods give almost the same mass, the difference being less than 1%.

EXAMPLE 8. If the earth were made of lead of relative density 11.3, what then would be the value of acceleration due to gravity on the surface of the earth? Radius of the earth $= 6.4 \times 10^6 \text{ m}$ and $G = 6.67 \times 10^{-11} \text{ Nm}^2 \text{ kg}^{-2}$.

Solution. Density of the earth,

$$\rho = \text{Relative density} \times \text{density of water}$$

$$= 11.3 \times 10^3 \text{ kg m}^{-3}$$

Acceleration due to gravity on the earth's surface,

$$g = \frac{GM}{R^2} = \frac{G}{R^2} \cdot \frac{4}{3} \pi R^3 \times \rho = \frac{4}{3} \pi GR\rho$$

$$= \frac{4}{3} \times \frac{22}{7} \times 6.67 \times 10^{-11} \times 6.4 \times 10^6 \times 11.3 \times 10^3$$

$$= 22.21 \text{ ms}^{-2}.$$

EXAMPLE 9. The acceleration due to gravity at the moon's surface is 1.67 ms^{-2} . If the radius of the moon is $1.74 \times 10^6 \text{ m}$, calculate the mass of the moon. Use the known value of G . [NCERT]

Solution. Here $G = 6.67 \times 10^{-11} \text{ Nm}^2 \text{ kg}^{-2}$,

$$g = 1.67 \text{ ms}^{-2}, R = 1.74 \times 10^6 \text{ m}$$

$$M = \frac{gR^2}{G} = \frac{1.67 \times (1.74 \times 10^6)^2}{6.67 \times 10^{-11}} = 7.58 \times 10^{22} \text{ kg.}$$

EXAMPLE 10. Two lead spheres of 20 cm and 2 cm diameter respectively are placed with centres 100 cm apart. Calculate the attraction between them, given the radius of the earth as $6.37 \times 10^8 \text{ cm}$ and its mean density as $5.53 \times 10^3 \text{ kg m}^{-3}$. Specific gravity of lead = 11.5. If the lead spheres are replaced by brass spheres of same radii, would the force of attraction be same?

Solution. Here $r_1 = \frac{20}{2} \text{ cm} = 0.10 \text{ m}$,

$$r_2 = \frac{2}{2} \text{ cm} = 0.01 \text{ m}$$

$$r = 1.0 \text{ m}, \rho' = 11.5 \times 10^3 \text{ kg m}^{-3}$$

$$R = 6.37 \times 10^8 \text{ cm} = 6.37 \times 10^6 \text{ m},$$

$$\rho = 5.53 \times 10^3 \text{ kg m}^{-3}$$

Masses of the two lead spheres will be

$$m_1 = \frac{4}{3} \pi r_1^3 \rho'$$

$$= \frac{4}{3} \times 3.14 \times (0.10)^3 \times 11.5 \times 10^3 = 48.15 \text{ kg}$$

$$m_2 = \frac{4}{3} \pi r_2^3 \rho'$$

$$= \frac{4}{3} \times 3.14 \times (0.01)^3 \times 11.5 \times 10^3 = 0.04815 \text{ kg}$$

$$\text{As } g = \frac{GM}{R^2} = \frac{G}{R^2} \times \frac{4}{3} \pi R^3 \rho$$

$$\therefore G = \frac{3g}{4\pi R\rho}$$

The force of attraction between the two lead spheres is

$$\begin{aligned}
 F &= G \frac{m_1 m_2}{r^2} = \frac{3g}{4\pi R\rho} \times \frac{m_1 m_2}{r^2} \\
 &= \frac{3 \times 9.8 \times 48.15 \times 0.04815}{4 \times 3.14 \times (6.37 \times 10^6)^2 \times 5.53 \times 10^3 \times (1)^2} \\
 &= 15.4 \times 10^{-11} \text{ N}
 \end{aligned}$$

As the density of brass is less than that of lead, the masses of brass spheres will be smaller than those of lead spheres, so the force of attraction ($F \propto m_1 m_2$) will decrease when lead spheres are replaced by brass spheres.

EXAMPLE 11. Compare the gravitational acceleration of the earth due to attraction of the sun with that due to attraction of the moon. Given that mass of sun, $M_s = 1.99 \times 10^{30}$ kg, mass of moon, $M_m = 7.35 \times 10^{22}$ kg, distance of sun from earth, $r_{es} = 1.49 \times 10^{11}$ m and distance of moon from earth $r_{em} = 3.84 \times 10^8$ m

Solution. Here $M_s = 1.99 \times 10^{30}$ kg

$$M_m = 7.35 \times 10^{22} \text{ kg}$$

$$r_{es} = 1.49 \times 10^{11} \text{ m}$$

and

$$r_{em} = 3.84 \times 10^8 \text{ m}$$

Let M_e be mass of earth. If g_{es} is acceleration of the earth due to the attraction of the sun, then

$$M_e g_{es} = G \frac{M_e M_s}{r_{es}^2} \quad \text{or} \quad g_{es} = \frac{GM_s}{r_{es}^2} \quad \dots(i)$$

If g_{em} is acceleration of earth due to the attraction of the moon, then

$$M_e g_{em} = G \frac{M_e M_m}{r_{em}^2} \quad \text{or} \quad g_{em} = \frac{GM_m}{r_{em}^2} \quad \dots(ii)$$

Dividing equation (i) by (ii), we get

$$\begin{aligned}
 \frac{g_{es}}{g_{em}} &= \frac{GM_s}{r_{es}^2} \times \frac{r_{em}^2}{GM_m} = \frac{M_s}{M_m} \times \frac{r_{em}^2}{r_{es}^2} \\
 &= \frac{1.99 \times 10^{30}}{7.35 \times 10^{22}} \times \frac{(3.84 \times 10^8)^2}{(1.49 \times 10^{11})^2} = 179.8
 \end{aligned}$$

$$\text{or} \quad g_{es} : g_{em} = 179.8 : 1$$

EXAMPLE 12. A body weighs 90 kg f on the surface of the earth. How much will it weigh on the surface of Mars whose mass is $1/9$ and the radius is $1/2$ of that of the earth?

Solution. The acceleration due to gravity on the surface of the earth is given by

$$g_e = \frac{GM_e}{R_e^2} \quad \dots(i)$$

The acceleration due to gravity on the surface of Mars is given by

$$g_m = \frac{GM_m}{R_m^2} \quad \dots(ii)$$

Dividing equation (ii) by (i), we get

$$\frac{g_m}{g_e} = \frac{M_m}{M_e} \left[\frac{R_e}{R_m} \right]^2 = \frac{1}{9} \times \left[\frac{2}{1} \right]^2 = \frac{4}{9}$$

$$\therefore g_m = \frac{4}{9} g_e$$

Weight on the surface of Mars,

$$W_m = mg_m = \frac{4}{9} mg_e = \frac{4}{9} \times 90 \text{ kg f} = 40 \text{ kg f.}$$

EXAMPLE 13. If the radius of the earth shrinks by 2.0%, mass remaining constant, then how would the value of acceleration due to gravity change? [Central Schools 09]

Solution. Acceleration due to gravity on the surface of the earth is given by

$$g = \frac{GM}{R^2}$$

Taking logarithm of both sides, we get

$$\log g = \log G + \log M - 2 \log R$$

As G and M are constant, so differentiation of the above equation gives

$$\frac{dg}{g} = 0 + 0 - 2 \frac{dR}{R}$$

As radius of the earth decreases by 2%, so

$$\begin{aligned}
 \frac{dR}{R} &= -\frac{2}{100} \\
 \frac{dg}{g} \times 100 &= -2 \frac{dR}{R} \times 100 \\
 &= -2 \times \left(-\frac{2}{100} \right) \times 100 = 4\%.
 \end{aligned}$$

Thus the value of g increases by 4%.

EXAMPLE 14. A man can jump 1.5 m high on the earth. Calculate the approximate height he might be able to jump on a planet whose density is one-quarter that of the earth and whose radius is one-third of the earth's radius.

Solution. Acceleration due to gravity on the earth's surface is given by

$$g = \frac{4}{3} \pi GR\rho$$

$$\text{On the planet,} \quad g' = \frac{4}{3} \pi GR'\rho'$$

$$\text{But} \quad R' = \frac{R}{3}, \quad \rho' = \frac{\rho}{4}$$

$$\therefore g' = \frac{4}{3} \pi G \times \frac{R}{3} \times \frac{\rho}{4} = \frac{1}{12} \times \frac{4}{3} \pi GR\rho = \frac{1}{12} g$$

Assuming that the man puts in the same energy in jumping high on the earth and the planet, then

$$mg'h' = mgh$$

$$\text{or } m \times \frac{1}{12} g \times h' = mgh$$

$$\text{or } h' = 12h = 12 \times 1.5 = 18 \text{ m.}$$

✱ PROBLEMS FOR PRACTICE

1. A spherical mass of 20 kg lying on the surface of the earth is attracted by another spherical mass of 150 kg with a force equal to the weight of 0.25 mg. The centres of the two masses are 30 cm apart. Calculate the mass of the earth. Radius of the earth = 6×10^6 m. (Ans. 4.8×10^{24} kg)
2. The period of moon around the earth is 27.3 days and radius of the orbit is 3.9×10^5 km. $G = 6.67 \times 10^{-11} \text{ Nm}^{-2} \text{ kg}^{-2}$, find the mass of the earth. (Ans. 6.31×10^{24} kg)
3. Assuming the earth to be a uniform sphere of radius 6400 km and density 5.5 gm cm^{-3} , find the value of g on its surface.
Given $G = 6.66 \times 10^{-11} \text{ Nm}^2 \text{ kg}^{-2}$. (Ans. 9.82 ms^{-2})
4. The mass of Jupiter is 314 times that of earth and the diameter of Jupiter is 11.35 times that of earth. If ' g ' has a value of 9.8 ms^{-2} on the earth, what is its value on Jupiter? (Ans. 23.90 ms^{-2})
5. The value of ' g ' on the surface of the earth is 9.81 ms^{-2} . Find its value on the surface of the moon. Given mass of earth = 6.4×10^{24} kg, radius of earth = 6.4×10^6 m, mass of moon = 7.4×10^{22} kg, radius of moon = 1.76×10^6 m. (Ans. 1.63 ms^{-2})
6. An astronaut on the moon measures the acceleration due to gravity to be 1.7 ms^{-2} . He knows that the radius of the moon is about 0.27 times that of the earth. Find the ratio of the mass of the earth to that of the moon, if the value of g on the earth's surface is 9.8 ms^{-2} . (Ans. 79)
7. The acceleration due to gravity on the surface of the earth is 10 ms^{-2} . The mass of the planet Mars as compared to earth is $1/10$ and radius is $1/2$. Determine the gravitational acceleration of a body on the surface of Mars. (Ans. 4 ms^{-2})
8. A body weighs 100 kg on earth. Find its weight on Mars. The mass and radius of Mars are $1/10$ and $1/2$ of the mass and radius of earth. (Ans. 40 kg wt)
9. The weight of a person on the earth is 80 kg. What will be his weight on the moon? Mass of the moon = 7.34×10^{22} kg, radius = 1.75×10^6 m and gravitational constant = $6.67 \times 10^{-11} \text{ Nm}^2 \text{ kg}^{-2}$.

What will be the mass of the person at the moon and acceleration due to gravity there? If this person can jump 2 m high on the earth, how much high can he jump at the moon?

(Ans. 128 N, 80 kg, 1.6 ms^{-2} , about 12 m)

10. On a planet whose size is the same and mass 4 times as that of the earth, find the energy needed to lift a 2 kg mass vertically upwards through 2 m distance in joule. The value of g on the surface of earth is 10 ms^{-2} . (Ans. 160 J)

✱ HINTS

1. Here $m_1 = 20 \text{ kg}$, $m_2 = 150 \text{ kg}$, $r = 30 \text{ cm} = 0.30 \text{ m}$
 $F = 0.25 \text{ mg wt} = 0.25 \times 10^{-6} \text{ kg wt}$
 $= 25 \times 10^{-8} \times 9.8 \text{ N}$
 $G = \frac{Fr^2}{m_1 m_2} = \frac{25 \times 9.8 \times 10^{-8} \times (0.3)^2}{20 \times 150}$
 $= 7.35 \times 10^{-11} \text{ Nm}^2 \text{ kg}^{-2}$

Mass of the earth,

$$M = \frac{g R^2}{G} = \frac{9.8 \times (6 \times 10^6)^2}{7.35 \times 10^{-11}} = 4.8 \times 10^{24} \text{ kg.}$$

4. Given $\frac{M_j}{M_e} = 314$

$$\frac{\text{Diameter of Jupiter}}{\text{Diameter of earth}} = 11.35$$

$$\therefore \frac{R_j}{R_e} = 11.35$$

$$\text{Now } g_e = \frac{GM_e}{R_e^2} \text{ and } g_j = \frac{GM_j}{R_j^2}$$

$$\therefore \frac{g_j}{g_e} = \frac{M_j}{M_e} \left[\frac{R_e}{R_j} \right]^2 = 314 \times \left(\frac{1}{11.35} \right)^2$$

$$\text{or } g_j = \frac{314}{11.35 \times 11.35} \times g_e = \frac{314 \times 9.8}{11.35 \times 11.35} = 23.90 \text{ ms}^{-2}.$$

$$\begin{aligned} 5. g_m &= \frac{M_m}{M_e} \left[\frac{R_e}{R_m} \right]^2 \times g_e \\ &= \frac{7.4 \times 10^{22}}{6 \times 10^{24}} \times \left[\frac{6.4 \times 10^6}{1.74 \times 10^6} \right]^2 \times 9.8 \\ &= \frac{7.4 \times 6.4 \times 6.4 \times 9.8 \times 10^{-2}}{6 \times 1.74 \times 1.74} = 1.63 \text{ ms}^{-2}. \end{aligned}$$

$$6. \text{ Here } g_e = \frac{GM_e}{R_e^2}$$

$$\text{and } g_m = \frac{GM_m}{R_m^2}$$

$$\therefore \frac{g_e}{g_m} = \frac{M_e}{M_m} \cdot \frac{R_m^2}{R_e^2}$$

$$\text{or } \frac{M_e}{M_m} = \frac{g_e}{g_m} \left[\frac{R_e}{R_m} \right]^2 = \frac{9.8}{1.7} \times \frac{1}{(0.27)^2} = 79.$$

$$9. \text{ Here } g_m = \frac{GM_m}{R_m^2} = \frac{6.67 \times 10^{-11} \times 7.34 \times 10^{22}}{(1.75 \times 10^6)^2} = 1.6 \text{ ms}^{-2}$$

Mass of the person on the moon = 80 kg

Weight on the moon = $mg = 80 \times 1.6 = 128 \text{ N}$

As $mg'h' = mgh$

$$\therefore h' = \frac{gh}{g'} = \frac{9.8 \times 2}{1.6} = 12 \text{ m.}$$

$$10. \text{ On the earth, } g = \frac{GM}{R^2};$$

$$\text{On the planet, } g' = \frac{4GM}{R^2} = 4g$$

$$\text{or } \frac{g_h}{g} = \frac{R^2}{(R+h)^2} \quad \dots(iii)$$

$$\text{or } \frac{g_h}{g} = \frac{R^2}{R^2 \left(1 + \frac{h}{R}\right)^2} = \left(1 + \frac{h}{R}\right)^{-2}$$

Expanding R.H.S. by using binomial theorem, we get $\frac{g_h}{g} = 1 - \frac{2h}{R} + \text{terms containing higher powers of } \frac{h}{R}$

If $h \ll R$, then $\frac{h}{R} \ll 1$, so that higher powers of $\frac{h}{R}$ can be neglected, we get

$$\frac{g_h}{g} = 1 - \frac{2h}{R}$$

$$\text{or } g_h = g \left(1 - \frac{2h}{R}\right) \quad \dots(iv)$$

Both equations (iii) and (iv) show that the value of acceleration due to gravity decreases with the increase in height h , that is why the value of g is less at mountains than at plains. While solving numerical problems, equation (iii) should be used when h is comparable to R and equation (iv) should be used when $h \ll R$.

8.11 ▽ VARIATIONS IN ACCELERATION DUE TO GRAVITY

17. What are the various factors on which the value of g at any place on the earth depends ?

Factors on which g depends. The value of g changes from place to place. It depends on various factors such as (i) altitude (ii) depth (iii) shape of the earth and (iv) rotation of the earth.

8.12 ▽ VARIATION OF g WITH ALTITUDE (HEIGHT)

18. Discuss the variation of g with altitude.

Effect of altitude on g . Consider the earth to be a sphere of mass M , radius R and centre O . Then the acceleration due to gravity at a point A on the surface of the earth will be

$$g = \frac{GM}{R^2} \quad \dots(i)$$

If g_h is the acceleration due to gravity at a point B at a height h from the earth's surface, then

$$g_h = \frac{GM}{(R+h)^2} \quad \dots(ii)$$

Dividing equation (ii) by (i), we get

$$\frac{g_h}{g} = \frac{GM}{(R+h)^2} \times \frac{R^2}{GM}$$

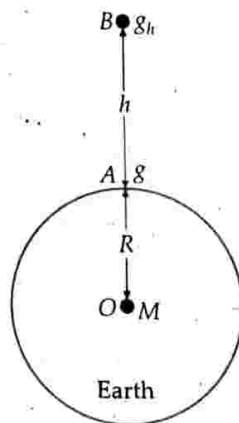

Fig. 8.13 Effect of altitude on g .

To Your Knowledge

▲ The decrease in the value of g at height h is

$$g - g_h = \frac{2gh}{R}$$

Clearly $g - g_h \propto h$

▲ The percentage decrease in the value of g at height h is

$$\frac{g - g_h}{g} \times 100 = \frac{2h}{R} \times 100\%$$

▲ The loss in weight of a body at a height h

$$= mg - mg_h = \frac{2mgh}{R}$$

▲ At an altitude $h = 320 \text{ km}$, $g_h = 0.9 g$, i.e., the value of g decreases by 10%.

▲ A typical space shuttle altitude is $h = 400 \text{ km}$.

Examples based on

Variation of g with Altitude

FORMULAE USED

$$1. g_h = g \cdot \frac{R^2}{(R+h)^2}, \text{ when } h \text{ is comparable to } R$$

$$2. g_h = g \left(1 - \frac{2h}{R}\right), \text{ when } h \ll R$$

UNITS USED

Here g and g_h are in ms^{-2} , and h and R are in metre.

EXAMPLE 15. At what height from the surface of the earth, will the value of g be reduced by 36% from the value at the surface? Radius of the earth = 6400 km. [Delhi 11]

Solution. Suppose at height h , the value of g reduces by 36% i.e., it becomes 64% of that at the surface. Thus

$$g_h = 64\% \text{ of } g = \frac{64}{100} g$$

$$\text{But } g_h = g \frac{R^2}{(R+h)^2}$$

$$\frac{64}{100} g = g \frac{R^2}{(R+h)^2} \quad \text{or} \quad \frac{8}{10} = \frac{R}{R+h}$$

$$\text{or} \quad h = \frac{R}{4} = \frac{6400}{4} = 1600 \text{ km.}$$

EXAMPLE 16. At what height above the earth's surface, the value of g is half of its value on earth's surface? Given its radius is 6400 km.

Solution. Here $g_h = g/2$

$$\text{But } g_h = g \left(\frac{R}{R+h} \right)^2$$

$$\therefore \frac{g}{2} = g \left(\frac{R}{R+h} \right)^2 \quad \text{or} \quad \left(\frac{R}{R+h} \right)^2 = \frac{1}{2}$$

$$\text{or} \quad \frac{R+h}{R} = \sqrt{2}$$

$$\text{or} \quad h = (\sqrt{2} - 1) R = 0.414 R = 0.414 \times 6400 = 2649.6 \text{ km.}$$

EXAMPLE 17. Find the percentage decrease in the weight of a body when taken to a height of 32 km above the surface of the earth. Radius of the earth is 6400 km. [Delhi 05]

Solution. Here $h = 32$ km, $R = 6400$ km

As $h \ll R$, so

$$g_h = g \left(1 - \frac{2h}{R} \right) = g - \frac{2gh}{R}$$

$$\text{or} \quad g - g_h = \frac{2gh}{R}$$

Percent decrease in weight

$$= \frac{mg - mg_h}{mg} \times 100 = \frac{g - g_h}{g} \times 100$$

$$= \frac{2gh}{g \times R} \times 100 = \frac{2h}{R} \times 100$$

$$= \frac{2 \times 32}{6400} \times 100 = 1\%.$$

EXAMPLE 18. A mass of 0.5 kg is weighed on a balance at the top of a tower 20 m high. The mass is then suspended from the pan of the balance by a fine wire 20 m long and is reweighed. Find the change in weight. Assume that the radius of the earth is 6400 km.

Solution. At a height h ($h \ll R$), we have

$$g_h = g \left(1 - \frac{2h}{R} \right) = g - \frac{2gh}{R}$$

$$\therefore g - g_h = \frac{2gh}{R}$$

$$\begin{aligned} \text{Change in weight} &= \text{Wt. at the foot of tower} \\ &\quad - \text{Wt. at the top of the tower} \\ &= mg - mg_h = m(g - g_h) = \frac{2mgh}{R} \end{aligned}$$

$$\text{But } mg = 0.5 \text{ kg f, } h = 20 \text{ m,} \\ R = 6400 \text{ km} = 6.4 \times 10^6 \text{ m.}$$

$$\therefore \text{Change in weight} \\ = \frac{2 \times 0.5 \times 20}{6.4 \times 10^6} = 3.125 \times 10^{-6} \text{ kg f.}$$

EXAMPLE 19. A body hanging from a spring stretches it by 1 cm at the earth's surface. How much will the same body stretch the spring at a place 1600 km above the earth's surface? Radius of the earth = 6400 km.

Solution. In equilibrium, weight of the suspended body = Stretching force

$$\therefore \text{At the earth's surface, } mg = k \times x$$

$$\text{At a height } h, \quad mg' = k \times x'$$

$$\frac{g'}{g} = \frac{x'}{x} = \frac{R^2}{(R+h)^2} = \frac{(6400)^2}{(6400+1600)^2}$$

$$= \left(\frac{6400}{8000} \right)^2 = \frac{16}{25}$$

$$\text{or} \quad x' = \frac{16}{25} \times x = \frac{16}{25} \times 1 \text{ cm} = 0.64 \text{ cm.}$$

✱ PROBLEMS FOR PRACTICE

- The radius of the earth is 6000 km. What will be the weight of a 120 kg body if it is taken to a height of 2000 km above the surface of the earth? (Ans. 67.5 kg f)
- A body of mass m is raised to a height h from the surface of the earth where the acceleration due to gravity is g . Prove that the loss in weight due to variation in g is approximately $2mgh/R$, where R is the radius of the earth.
- The Mount Everest is 8848 m above sea level. Estimate the acceleration due to gravity at this height, given that mean g on the surface of the earth is 9.8 ms^{-2} and mean radius of the earth is $6.37 \times 10^6 \text{ m}$. (Ans. 9.772 ms^{-2})
- At what height above the surface of the earth will the acceleration due to gravity be 25% of its value on the surface of the earth? Assume that the radius of the earth is 6400 km. (Ans. 6400 km)

5. Find the value of g at a height of 400 km above the surface of the earth. Given radius of the earth, $R = 6400$ km and value of g at the surface of the earth $\approx 9.8 \text{ ms}^{-2}$. [Central Schools 12]

(Ans. 8.575 ms^{-2})

6. How far away from the surface of earth does the acceleration due to gravity become 4% of its value on the surface of earth? Radius of earth = 6400 km.

[Delhi 98] (Ans. 25,600 km)

✗ HINTS

1. Here $mg = 120 \text{ kg f}$, $h = 200 \text{ km}$, $R = 6000 \text{ km}$

$$g_h = \left(\frac{R}{R+h} \right)^2 g = \left(\frac{6000}{8000} \right)^2 \times g = \frac{9}{16} g$$

$$\therefore mg_h = \frac{9}{16} mg = \frac{9}{16} \times 120 = 67.5 \text{ kg f.}$$

2. For $h < R$,

$$g_h = g \left(1 - \frac{2h}{R} \right) = g - \frac{2gh}{R}$$

$$\text{or } g - g_h = \frac{2gh}{R}$$

\therefore Loss in weight due to variation in g

$$= mg - mg_h = m(g - g_h)$$

$$= \frac{m \times 2gh}{R} = \frac{2mgh}{R}$$

3. Here $h = 8848 \text{ m}$, $g = 9.8 \text{ ms}^{-2}$, $R = 6.37 \times 10^6 \text{ m}$
Acceleration due to gravity at height h (when $h < R$) is given by

$$g_h = g \left(1 - \frac{2h}{R} \right) = 9.8 \left(1 - \frac{2 \times 8848}{6.37 \times 10^6} \right)$$

$$= 9.8(1 - 0.002778) = 9.772 \text{ ms}^{-2}.$$

$$6. \quad \frac{4}{100} g = g \left(\frac{R}{R+h} \right)^2$$

$$\frac{2}{10} = \frac{R}{R+h}$$

$$h = 4R = 4 \times 6400 = 25,600 \text{ km.}$$

$$g = \frac{G \times \frac{4}{3} \pi R^3 \rho}{R^2}$$

$$\text{or } g = \frac{4}{3} \pi G R \rho$$

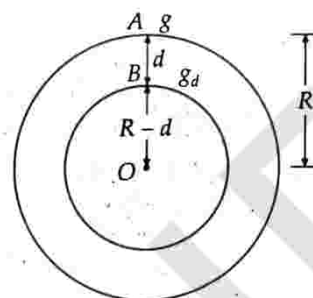

Fig. 8.14 Effect of depth on g .

Let g_d be the acceleration due to gravity at a point B at depth d below the surface of the earth. A body at B is situated at the surface of inner solid sphere and lies inside the spherical shell of thickness d . The gravitational force of attraction on a body inside a spherical shell is always zero. Therefore, a body at B experiences gravitational force due to inner shaded sphere of radius $(R-d)$ and mass M' , where

$$M' = \frac{4}{3} \pi (R-d)^3 \rho$$

$$g_d = \frac{GM'}{(R-d)^2} = \frac{G}{(R-d)^2} \times \frac{4}{3} \pi (R-d)^3 \rho$$

$$\text{or } g_d = \frac{4}{3} \pi G (R-d) \rho$$

$$\frac{g_d}{g} = \frac{\frac{4}{3} \pi G (R-d) \rho}{\frac{4}{3} \pi G R \rho} = \frac{R-d}{R} = 1 - \frac{d}{R}$$

$$\text{or } g_d = g \left(1 - \frac{d}{R} \right)$$

Clearly, the acceleration due to gravity decreases with the increase in depth d . That is why the acceleration due to gravity is less in mines than that on earth's surface.

20. How much will be the weight of a body at the centre of the earth?

Weight of a body at the centre of the earth. At the centre of the earth, $d = R$,

$$g_d = g \left(1 - \frac{R}{R} \right) = 0$$

Weight of a body of mass m at the centre of the earth,

$$= mg_d = m \times 0 = 0.$$

Hence the weight of a body at the centre of the earth is zero though its mass is not zero.

8.13 ▽ VARIATION OF g WITH DEPTH

19. Discuss the variation of g with depth.

Effect of depth on g . Consider the earth to be a sphere of mass M , radius R and centre O . The acceleration due to gravity at any point A on the surface of the earth will be

$$g = \frac{GM}{R^2}$$

Assuming the earth to be a homogeneous sphere of average density ρ , then its total mass will be

$$M = \text{Volume} \times \text{density} = \frac{4}{3} \pi R^3 \rho$$

For Your Knowledge

▲ The acceleration due to gravity decreases both with the increase in height and increase in depth. So it is maximum at the surface of the earth and zero at the centre of the earth.

▲ Decrease in the value of g at depth d is

$$g - g_d = \frac{d}{R} g$$

▲ Percentage decrease in the value of g at depth d is

$$\frac{g - g_d}{g} \times 100 = \frac{d}{R} \times 100\%$$

21. What is the relation between height h and depth d for the same change in g ?

Relation between height h and depth d for the same change in g . Acceleration due to gravity at a height h above the earth's surface,

$$g_h = g \left(1 - \frac{2h}{R} \right)$$

Acceleration due to gravity at a depth d below the earth's surface,

$$g_d = g \left(1 - \frac{d}{R} \right)$$

For the same change in g , we have

$$g_h = g_d$$

$$\therefore 1 - \frac{2h}{R} = 1 - \frac{d}{R} \quad \text{or} \quad \frac{2h}{R} = \frac{d}{R} \quad \text{or} \quad d = 2h$$

Hence the acceleration due to gravity at a height h above the earth's surface will be same as that at depth $d = 2h$, below the earth's surface. But this fact holds only when $h \ll R$.

Examples based on

Variation of ' g ' with Depth

FORMULAE USED

1. At a depth d , $g_d = g \left(1 - \frac{d}{R} \right)$

2. When $d = 2h$, $g_h = g_d$

UNITS USED

Here g and g_h and g_d are in ms^{-2} , and d , h and R are in metre.

EXAMPLE 20. Find the percentage decrease in weight of a body, when taken 16 km below the surface of the earth. Take radius of the earth as 6400 km.

Solution. Here $R = 6400$ km, $d = 16$ km

$$g_d = g \left(1 - \frac{d}{R} \right) = g \left(1 - \frac{16}{6400} \right) = \frac{399}{400} g$$

$$\therefore g - g_d = g - \frac{399}{400} g = \frac{1}{400} g$$

The percentage decrease in weight of the body

$$\begin{aligned} &= \frac{mg - mg_d}{mg} \times 100 = \frac{g - g_d}{g} \times 100 \\ &= \frac{(1/400)g}{g} \times 100 = 0.25\%. \end{aligned}$$

EXAMPLE 21. How much below the surface of the earth does the acceleration due to gravity become 1% of its value at the earth's surface? Radius of the earth = 6400 km.

Solution. Here $g_d = 1\%$ of $g = \frac{g}{100}$

But $g_d = g \left(1 - \frac{d}{R} \right)$

$$\therefore \frac{g}{100} = g \left(1 - \frac{d}{R} \right)$$

or $\frac{d}{R} = 1 - \frac{1}{100} = \frac{99}{100}$

or $d = \frac{99}{100} \times R = \frac{99}{100} \times 6400 = 6336$ km.

EXAMPLE 22. At what height above the earth's surface, the value of g is same as in a mine 80 km deep?

Solution. Let h be the height at which ' g ' is same as that at depth d . Now

$$g_h = g_d \quad \text{or} \quad g \left(1 - \frac{2h}{R} \right) = g \left(1 - \frac{d}{R} \right)$$

or $\frac{2h}{R} = \frac{d}{R}$

$$\therefore h = \frac{d}{2} = \frac{80}{2} = 40$$
 km.

EXAMPLE 23. Imagine a tunnel dug along a diameter of the earth. Show that a particle dropped from one end of the tunnel executes simple harmonic motion. What is the time period of this motion? Assume the earth to be a sphere of uniform mass density (equal to its known average density = 5520 kg m^{-3} .) $G = 6.67 \times 10^{-11} \text{ Nm}^2 \text{ kg}^{-2}$. Neglect all damping forces.

Solution. The acceleration due to gravity at a depth d below the earth's surface is given by

$$g_d = g \left(1 - \frac{d}{R} \right)$$

or $g_d = g \left(\frac{R - d}{R} \right) = \frac{g}{R} y$

where $y = R - d =$ Distance of the body from the centre of the earth.

Thus $g_d \propto y$

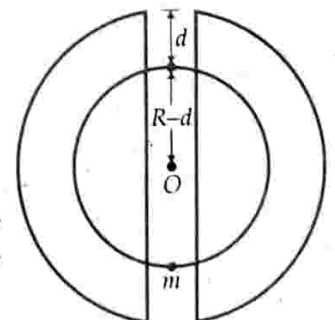

Fig. 8.15

As the acceleration is proportional to displacement and is directed towards the mean position, so the motion of the body is simple harmonic. Its time period is given by

$$T = 2\pi \sqrt{\frac{\text{Displacement}}{\text{Acceleration}}} = 2\pi \sqrt{\frac{y}{g_d}} = 2\pi \sqrt{\frac{R}{g}}$$

$$\text{But } g = \frac{GM}{R^2} = \frac{G}{R^2} \times \frac{4}{3} \pi R^3 \rho = \frac{4}{3} \pi GR\rho$$

$$\therefore T = 2\pi \sqrt{\frac{R}{\frac{4}{3} \pi GR\rho}} = 2\pi \sqrt{\frac{3}{4 \pi G\rho}} = \sqrt{\frac{3\pi}{G\rho}}$$

$$\therefore = \sqrt{\frac{3 \times 3.142}{6.67 \times 10^{-11} \times 5520}} = 5059.77 \text{ s.}$$

X PROBLEMS FOR PRACTICE

- Find the value of acceleration due to gravity in a mine at a depth of 80 km from the surface of the earth. Radius of the earth = 6400 km. (Ans. 9.68 ms^{-2})
- Calculate the depth below the surface of the earth where acceleration due to gravity becomes half of its value at the surface of the earth. Radius of the earth = 6400 km. (Ans. 3200 km)
- How much below the surface of the earth does the acceleration due to gravity become 70% of its value at the surface of the earth? Radius of the earth is 6400 km. (Ans. 1920 km)
- How much below the surface of the earth does the acceleration due to gravity (i) reduce to 36% (ii) reduce by 36% of its value on the surface of the earth? Radius of the earth = 6400 km.
[Ans. (i) 4096 km (ii) 2304 km]
- Compare the weights of a body when it is (i) 100 km above the surface of the earth and (ii) 100 km below the surface of the earth. Radius of the earth is 6300 km. (Ans. 0.984)

X HINTS

$$5. \text{ At a height } h, \quad g_h = g \left(1 - \frac{2h}{R}\right)$$

$$\text{At a depth } d, \quad g_d = g \left(1 - \frac{d}{R}\right)$$

$$\frac{g_h}{g_d} = \frac{1 - \frac{2h}{R}}{1 - \frac{d}{R}} = \frac{R - 2h}{R - d}$$

$$\text{or } \frac{W_h}{W_d} = \frac{mg_h}{mg_d} = \frac{R - 2h}{R - d}$$

$$\text{But } R = 6300 \text{ km, } h = 100 \text{ km, } d = 100 \text{ km}$$

$$\therefore \frac{W_h}{W_d} = \frac{6300 - 200}{6300 - 100} = \frac{6100}{6200} = 0.984.$$

8.14 VARIATION OF g WITH SHAPE OF THE EARTH

22. Discuss the variation of g on earth's surface due to shape of the earth. Why does the weight of a body increase when it is taken from the equator to the pole?

Effect of shape of earth on g . Earth is not perfect sphere. It is flattened at the poles and bulges out at the equator. So the equatorial radius R_e of the earth is greater than the polar radius R_p by about 21 km.

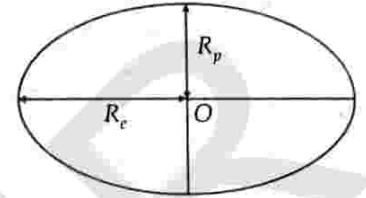

Fig. 8.16 Equatorial and polar radii of the earth.

Acceleration due to gravity on the earth's surface is given by

$$g = \frac{GM}{R^2}$$

$$\text{i.e., } g \propto \frac{1}{R^2} \quad [\because G, M \text{ are constant}]$$

$$\text{As } R_e > R_p, \text{ so } g_e < g_p.$$

Thus the value of g is minimum at the equator and maximum at the poles. That is why the weight of a body increases when it is taken from the equator to the pole. The variation of g between the poles and the equator is about 0.5%.

8.15 VARIATION OF ' g ' WITH LATITUDE (OR ROTATION OF THE EARTH)

23. Define latitude at a place.

Latitude. The plane passing through the centre of the earth and perpendicular to its axis of rotation is called its equatorial plane. The latitude of a place is defined as the angle which the line joining the place to the centre of the earth makes with the equatorial plane. In Fig. 8.17, the latitude of place $P = \angle POE = \lambda$. Clearly, $\lambda = 0^\circ$ at the equator and $\lambda = 90^\circ$ at the poles.

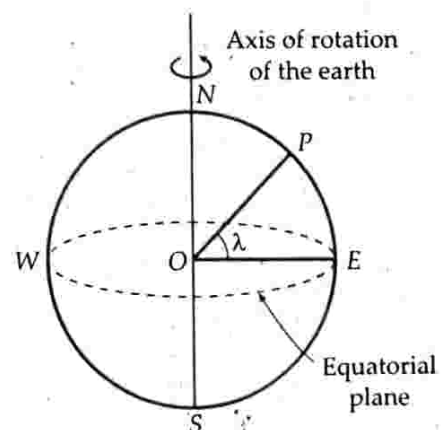

Fig. 8.17 Latitude.

24. Explain how is the acceleration due to gravity affected at a latitude due to the rotational motion of the earth.

Effect of latitude or rotation of earth on g . Refer to Fig. 8.18. As the earth rotates about its polar axis, every particle lying on its surface also revolves along a horizontal circle with the same angular velocity ω .

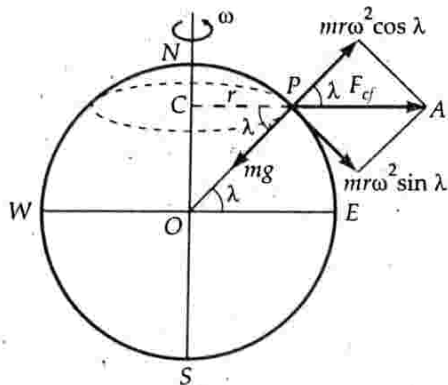

Fig. 8.18 Effect of rotation on g .

Consider a particle of mass m lying at point P , whose latitude is λ . The particle P describes a horizontal circle of radius,

$$r = PC = R \cos \lambda$$

The centrifugal force acting on the particle is $F_{cf} = mr\omega^2$, acting along PA

This force has two rectangular components: $mr\omega^2 \cos \lambda$ and $mr\omega^2 \sin \lambda$. The component $mr\omega^2 \sin \lambda$ acts perpendicular to mg and has no effect on it. The component $mr\omega^2 \cos \lambda$ acts opposite to mg . So the apparent weight of the particle P is

$$mg_{\lambda} = mg - mr\omega^2 \cos \lambda$$

$$\text{or } g_{\lambda} = g - r\omega^2 \cos \lambda$$

$$\text{or } g_{\lambda} = g - R\omega^2 \cos^2 \lambda \quad [\because r = R \cos \lambda]$$

As λ increases, $\cos \lambda$ decreases and g_{λ} increases. So as we move from equator to pole, the acceleration due to gravity increases.

Special cases :

(i) At the equator. $\lambda = 0^\circ$, $\cos \lambda = 1$, hence

$$g_e = g - R\omega^2$$

(ii) At the poles. $\lambda = 90^\circ$, $\cos \lambda = 0$, hence

$$g_p = g - R\omega^2 \times 0 = g$$

Thus acceleration due to gravity is minimum at the equator and maximum at the poles. The difference in the two values is

$$g_p - g_e = g - (g - R\omega^2) = R\omega^2$$

25. Draw a graph showing the variation of acceleration due to gravity g with distance r from the centre of the earth.

For points lying outside the earth ($r > R$),

$$\frac{g_h}{g} = \frac{R^2}{(R+h)^2} = \frac{R^2}{r^2} \quad \text{or} \quad g_h = \frac{gR^2}{r^2}$$

$$\Rightarrow g_h \propto \frac{1}{r^2}$$

For points lying inside the earth ($r < R$),

$$g_d = \frac{g(R-d)}{R} = \frac{gr}{R} \quad \text{or} \quad g_d = \frac{gr}{R}$$

$$\Rightarrow g_d \propto r$$

Hence the graph showing the variation of acceleration due to gravity g with distance r from the centre of the earth is of the type as shown in Fig. 8.19.

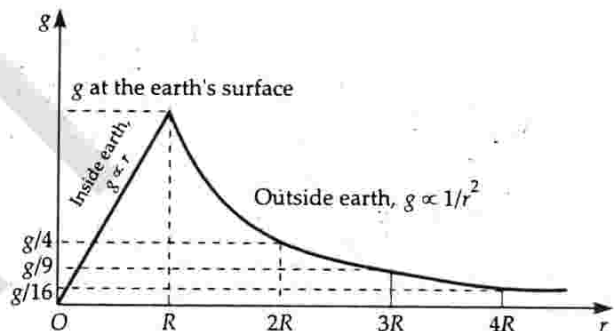

Figure 8.19 Variation of g with distance r from the centre of the earth.

8.16 VARIATION OF 'g' DUE TO OTHER FACTORS

26. State some factors (other than altitude, depth and latitude) on which g depends. What is the utility of measuring g accurately on earth surface?

Variation of g due to other factors. The earth's surface is uneven. It has mountains, plateaus and valleys. This causes a variation in the value of g . Moreover, the density of earth is not uniform. Its inner core is heavier than the mantle. Also, the density of earth's crust varies from place to place. Hence the value of g is different at different places.

When g is measured accurately, its variations indicate the presence of oil and heavy minerals. Hence such studies are useful in oil and mineral explorations.

For Your Knowledge

- ▲ Acceleration due to gravity decreases due to rotation of the earth ($g' < g$).
- ▲ Acceleration due to gravity increases with the increase in latitude of the place.
- ▲ The effect of rotation of the earth is maximum at the equator and minimum at the poles. In fact, rotational motion of the earth has no effect on the value of g at the poles.
- ▲ If the earth stops rotating, the weight of a body would increase due to the absence of the centrifugal force.
- ▲ Both the rotation of the earth and its equatorial bulg contribute additively to lower the value of g at the equator than at the poles.
- ▲ Even for the rotating earth, the direction of acceleration due to gravity is towards the centre of the earth both at the equator ($\lambda = 0^\circ$) and at the poles ($\lambda = \pm 90^\circ$). At intermediate latitudes, this direction slightly deviates from the centre of the earth. The maximum deviation is about 0.1° .

Examples based on

Variation of 'g' with Rotation of the Earth

FORMULAE USED

1. At latitude λ , $g_\lambda = g - R\omega^2 \cos^2 \lambda$
2. At equator, $\lambda = 0^\circ$, so $g_e = g - R\omega^2$
3. At poles, $\lambda = 90^\circ$, so $g_p = g$
4. $g_p - g_e = R\omega^2$

UNITS USED

Here g, g_e, g_p, g_λ are in ms^{-2} , latitude λ in degrees, angular velocity ω in rad s^{-1} , and R in metre.

EXAMPLE 24. Calculate that imaginary angular velocity of the earth for which effective acceleration due to gravity at the equator becomes zero. In this condition what will be the length (in hours) of the day? Given radius of the earth = 6400 km and $g = 10 \text{ ms}^{-2}$.

Solution. At latitude λ , $g_\lambda = g - R\omega^2 \cos^2 \lambda$

At equator, $\lambda = 0^\circ$, so $g_e = g - R\omega^2$

When $g_e = 0$, we have,

$$\omega = \sqrt{\frac{g}{R}} = \sqrt{\frac{10}{6400 \times 10^3}} = 1.25 \times 10^{-3} \text{ rad s}^{-1}$$

In this condition, the new period of rotation or the length of the day will be

$$T = \frac{2\pi}{\omega} = \frac{2 \times 3.14}{1.25 \times 10^{-3}} = 5024 \text{ s} = 1.4 \text{ h.}$$

EXAMPLE 25. Determine the speed with which the earth would have to rotate on its axis so that a person on the equator would weigh 3/5th as much as at present. Take the equatorial radius as 6400 km. [Roorkee 88]

Solution. Acceleration due to gravity at the equator is

$$g_e = g - R\omega^2$$

$$mg_e = mg - mR\omega^2$$

or $\frac{3}{5} mg = mg - mR\omega^2$ [$\because mg_e = \frac{3}{5} mg$]

$$\omega = \sqrt{\frac{2g}{5R}} = \sqrt{\frac{2 \times 9.8}{5 \times 6400 \times 10^3}} = 7.8 \times 10^{-4} \text{ rad s}^{-1}$$

EXAMPLE 26. If the earth were a perfect sphere of radius $6.37 \times 10^6 \text{ m}$, rotating about its axis with a period of 1 day ($= 8.64 \times 10^4 \text{ s}$), how much would the acceleration due to gravity (g) differ from the poles to the equator?

Solution. Acceleration due to gravity at the latitude λ is given by $g_\lambda = g - R\omega^2 \cos^2 \lambda$

At equator, $\lambda = 0^\circ$,

$$g_e = g - R\omega^2$$

At poles, $\lambda = 90^\circ$, so $g_p = g$

$$g_p - g_e = g - (g - R\omega^2)$$

$$= R\omega^2 = \frac{4\pi^2 R}{T^2}$$
[$\because \omega = \frac{2\pi}{T}$]

But $T = 1 \text{ day} = 8.64 \times 10^4 \text{ s}$, $R = 6.37 \times 10^6 \text{ m}$

$$g_p - g_e = \frac{4 \times 9.87 \times 6.37 \times 10^6}{(8.64 \times 10^4)^2}$$

$$= 3.37 \times 10^{-2} \text{ ms}^{-2} = 3.4 \text{ cms}^{-2}$$

PROBLEMS FOR PRACTICE

1. Calculate the value of acceleration due to gravity at a place of latitude 45° . Radius of the earth = $6.38 \times 10^3 \text{ km}$. (Ans. 9.783 ms^{-2})
2. If the earth stops rotating about its axis, then what will be the change in the value of g at a place in the equatorial plane? Radius of the earth = 6400 km. (Ans. 3.4 cms^{-2})
3. Assuming that the whole variation of the weight of a body with its position on the surface of the earth is due to its rotation, find the difference in the weight of 5 kg as measured at the equator and at the poles. Radius of the earth = $6.4 \times 10^6 \text{ m}$. (Ans. 17.2 gf)
4. How many times faster than its present speed the earth should rotate so that the apparent weight of an object at equator becomes zero? Given radius of the earth = $6.37 \times 10^6 \text{ m}$. What would be the duration of the day in that case? (Ans. 17 times faster, 1.412 h)

X HINTS

1. Here $\lambda = 45^\circ$, $R = 6.38 \times 10^6 \text{ m}$, $g = 9.8 \text{ ms}^{-2}$

$$\omega = \frac{2\pi}{T} = \frac{2\pi}{24 \times 60 \times 60} = 7.27 \times 10^{-5} \text{ rad s}^{-1}$$

$$g_\lambda = g - R\omega^2 \cos^2 \lambda$$

$$= 9.8 - 6.38 \times 10^6 \times (7.27 \times 10^{-5})^2 \times (\cos 45^\circ)^2$$

$$= 9.8 - 0.01687 = 9.783 \text{ ms}^{-2}$$

2. Change in the value of g

$$= g - g_e = R\omega^2 = R \left(\frac{2\pi}{T} \right)^2$$

$$= 6.4 \times 10^6 \times \left(\frac{2\pi}{24 \times 60 \times 60} \right)^2$$

$$= 3.37 \times 10^{-2} \text{ ms}^{-2} \approx 3.4 \text{ cms}^{-2}$$

3. Change in the weight of the body when taken from pole to equator

$$= m(g_p - g_e) = mR\omega^2 = mR \left(\frac{2\pi}{T} \right)^2$$

$$= 5 \times 3.37 \times 10^{-2} \text{ newton}$$

$$= \frac{5 \times 3.37 \times 10^{-2}}{9.8} \text{ kg f} = 17.2 \text{ gf}$$

4. At the equator, we have

$$g_\lambda = g - R\omega_1^2 \quad \text{or} \quad mg_\lambda = mg - mR\omega_1^2$$

As the apparent weight at equator is zero,

$$\text{so} \quad mg_\lambda = 0$$

$$\therefore mg - mR\omega_1^2 = 0$$

$$\text{or} \quad g = R\omega_1^2$$

$$\therefore \omega_1 = \sqrt{\frac{g}{R}} = \sqrt{\frac{9.8}{6.37 \times 10^6}} = 1.241 \times 10^{-3} \text{ rad s}^{-1}$$

But the present speed of the earth is

$$\omega = \frac{2\pi}{T} = \frac{2\pi}{24 \times 60 \times 60} = 7.27 \times 10^{-5} \text{ rad s}^{-1}$$

$$\therefore \frac{\omega_1}{\omega} = \frac{1.241 \times 10^{-3}}{7.27 \times 10^{-5}} = 17.06 \approx 17$$

$$\text{or} \quad \omega_1 = 17 \omega$$

i.e. the earth should rotate 17 times faster than its present speed.

$$\text{New duration of the day} = \frac{24}{17} = 1.412 \text{ h}$$

8.17 ▽ GRAVITATIONAL FIELD

27. Give the concept of gravitational field.

Gravitational field. Two bodies attract each other by the gravitational force even if they are not in direct

contact. This interaction is called *action at a distance*. It can be best explained in terms of concept of field. According to the field concept,

(i) Every mass modifies the space around it. This modified space is called gravitational field.

(ii) When any other mass is placed in this field, it feels a gravitational force of attraction due to its interaction with the gravitational field.

The space surrounding a material body within which its gravitational force of attraction can be experienced is called its gravitational field.

The earth is surrounded by a gravitational field. Any body brought in this field experiences a force of attraction towards the centre of the earth.

8.18 ▽ INTENSITY OF GRAVITATIONAL FIELD

28. Define intensity of gravitational field at any point. Is it a scalar or vector ?

Intensity of gravitational field or gravitational field strength. The gravitational field intensity at any point in the gravitational field due to a given mass is defined as the force experienced by a unit mass placed at that point provided the presence of unit mass does not disturb the original gravitational field.

The gravitational field intensity is a vector quantity, denoted by \vec{E} . It always acts towards the mass producing the gravitational field.

29. Show that gravitational field intensity at any point is equal to the free acceleration of a test mass placed at that point.

Ans. Intensity of gravitational field due to a body. Consider a body of mass M . To determine its gravitational field intensity at a point P at distance r from its centre O , place a test mass m ($m < M$) at the point P .

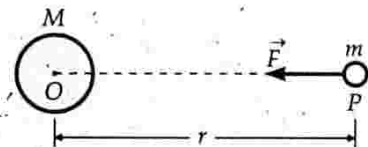

Fig. 8.20 Gravitational field intensity.

Let \vec{F} be the force of gravitation experienced by test mass m . The gravitational field intensity at point P will be

$$\vec{E} = \frac{\vec{F}}{m} \quad \dots(i)$$

The direction of \vec{E} is same as that of \vec{F} .

According to Newton's law of gravitation,

$$F = \frac{GMm}{r^2}$$

$$E = \frac{F}{m} = \frac{GM}{r^2} \quad \dots(ii)$$

At $r = \infty$, $E = 0$. Thus gravitational field intensity decreases as distance r increases and becomes zero at infinity.

If the test mass m is free to move, it will move towards the mass M with acceleration a under the force F , so

$$a = \frac{F}{m} \quad \dots(iii)$$

From equations (ii) and (iii), we get $a = E$

Thus the intensity of gravitational field at any point is equal to the free acceleration produced in the test mass when placed at that point.

30. Show that the gravitational field intensity of the earth at any point is equal to the acceleration produced in the freely falling body at that point.

Intensity of gravitational field due to earth. As shown in Fig. 8.21, let earth be a sphere of radius R and mass M . Suppose a test mass m be placed at a point P at distance r from its centre O . According to Newton's law of gravitation, the force of attraction on test mass m is

$$F = \frac{GMm}{r^2}$$

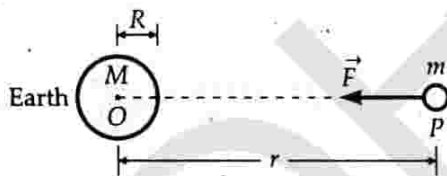

Fig. 8.21. Gravitational field intensity due to earth.

The gravitational field intensity at point P will be

$$E = \frac{F}{m} = \frac{GM}{r^2}$$

But GM/r^2 is equal to the acceleration due to gravity at the point P . Hence the gravitational field intensity of the earth at any point is equal to acceleration produced in the freely falling body at that point.

For any point on the surface of the earth, $r = R$, so

$$E_{\text{surface}} = \frac{GM}{R^2} = g$$

This is the acceleration due to gravity at the surface of the earth.

31. Give the units and dimensions of gravitational field intensity.

Units of E . As gravitational field intensity is force per unit mass, so its SI unit is Nkg^{-1} and cgs unit is dyn g^{-1} .

Dimensions of E . As $E = \frac{F}{m}$

$$\therefore \text{Dimensions of } E = \frac{\text{MLT}^{-2}}{\text{M}} = [\text{LT}^{-2}]$$

8.19 ▽ GRAVITATIONAL POTENTIAL ENERGY

32. What is meant by gravitational potential energy of a body? What is the zero level of potential energy?

Gravitational potential energy. When two bodies are placed close to one another, they interact through the gravitational force. Due to this, they possess mutual gravitational potential energy. When the distance between the two bodies is changed, work is done either by the gravitational force between the two bodies or against this force. In either case, the gravitational potential energy of the bodies changes.

The gravitational potential energy of a body is the energy associated with it due to its position in the gravitational field of another body and is measured by the amount of work done in bringing a body from infinity to a given point in the gravitational field of the other.

When one body lies at infinity from another body, the gravitational force on it is zero. Consequently its potential energy is zero. This is called zero level of potential energy.

33. Derive an expression for the gravitational potential energy of a body of mass m located at distance r from the centre of the earth.

Expression for gravitational potential energy. As shown in Fig. 8.22, suppose the earth is a uniform sphere of mass M and radius R . We wish to calculate the potential energy of a body of mass m located at point P such that $OP = r$ and $r > R$.

Suppose at any instant the body is at point A such that

$$OA = x$$

The gravitational force of attraction on the body at A is

$$F = \frac{GMm}{x^2}$$

The small work done in moving the body through small distance $AB (= dx)$ is given by

$$dW = Fdx = \frac{GMm}{x^2} dx$$

The total work done in bringing the body from infinity ($x = \infty$) to the point P ($x = r$) will be

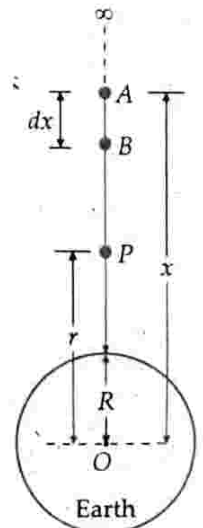

Fig. 8.22 Gravitational P.E. due to earth.

$$W = \int dW = \int_{\infty}^r \frac{GMm}{x^2} dx = GMm \int_{\infty}^r x^{-2} dx$$

$$= GMm \left[-\frac{1}{x} \right]_{\infty}^r = -GMm \left[\frac{1}{r} - \frac{1}{\infty} \right] = -\frac{GMm}{r}$$

By definition, this work done is the gravitational potential energy U of the body of mass m located at distance r from the centre of the earth.

$$U = -\frac{GMm}{r} \quad \dots(i)$$

Some important points :

1. The negative sign in equation (i) indicates that the potential energy is due to the gravitational attraction between the earth and the body. When the body is brought from infinity to a distance r , work is done by the gravitational force of attraction. As the mutual energy of the two bodies is expended, so their energy reduces by this amount.

2. As the distance r increases, the gravitational P.E. increases because it becomes zero i.e., maximum.

3. If a body of mass m is moved from a point at distance r_1 to a point at distance r_2 , then the change in potential energy of the body will be

$$\Delta U = \int_{r_1}^{r_2} \frac{GMm}{x^2} dx = GMm \left[-\frac{1}{x} \right]_{r_1}^{r_2}$$

$$= GMm \left[\frac{1}{r_1} - \frac{1}{r_2} \right]$$

If $r_1 > r_2$, then ΔU be negative. So when a body is brought closer to the earth, its gravitation P.E. decreases.

4. If a body is moved from the surface of the earth ($r_1 = R$) to a point at height h above the surface of the earth ($r_2 = R + h$), then the change in its gravitation P.E. will be

$$\Delta U = GMm \left[\frac{1}{R} - \frac{1}{R+h} \right] = \frac{GMm}{R} \left[1 - \frac{R}{R+h} \right]$$

$$= \frac{GMm}{R} \left[1 - \frac{1}{\left(1 + \frac{h}{R}\right)} \right]$$

$$= \frac{GMm}{R} \left[1 - \left(1 + \frac{h}{R}\right)^{-1} \right]$$

Applying binomial theorem, we get

$$\Delta U = \frac{GMm}{R} \left[1 - \left(1 - \frac{h}{R} + \text{terms containing higher powers of } \frac{h}{R} \right) \right]$$

If $h \ll R$, then higher powers of h/R can be neglected.

$$\text{Hence } \Delta U = \frac{GMm}{R} \left[1 - \left(1 - \frac{h}{R} \right) \right] = \frac{GMmh}{R^2}$$

But $\frac{GM}{R^2} = g =$ acceleration due to gravity on the earth's surface.

$$\therefore \Delta U = mgh$$

8.20 ▽ GRAVITATIONAL POTENTIAL

34. Define the term gravitational potential. Is it a scalar or vector? Give the units and dimensions of gravitational potential.

Gravitational potential. The gravitational potential at a point is the potential energy associated with a unit mass due to its position in the gravitational field of another body.

The gravitational potential at a point in the gravitational field of a body is defined as the amount of work done in bringing a body of unit mass from infinity to that point.

Gravitational potential,

$$V = \frac{\text{Work done}}{\text{Mass}} = \frac{W}{m}$$

The gravitational potential is a scalar quantity. Its SI unit is Jkg^{-1} and cgs units is erg g^{-1} .

The dimensional formula of gravitational potential is $[\text{M}^0\text{L}^2\text{T}^{-2}]$.

35. Derive expression for the gravitational potential at a point in the gravitational field of the earth. How is gravitational P.E. related to gravitational potential?

Gravitational potential at a point due to the earth.

The work done in bringing a body of mass m from infinity to a point at distance r from the centre of the earth is

$$W = -\frac{GMm}{r}$$

Hence the gravitational potential due to the earth at distance r from its centre is

$$V = \frac{W}{m} = -\frac{GM}{r}$$

At the surface of the earth, $r = R$, therefore

$$V_{\text{surface}} = -\frac{GM}{R}$$

Relation between gravitational potential energy and gravitational potential. From the above equations, we find that

$$U = -\frac{GMm}{r} = \left(-\frac{GM}{r} \right) \times m$$

\therefore Gravitational potential energy
= Gravitational potential \times mass

Examples based on Gravitational Intensity, Potential and Potential Energy

FORMULAE USED

- Intensity of gravitational field, $E = \frac{F}{m} = \frac{GM}{r^2}$
- Gravitational potential, $V = \frac{\text{Work done}}{\text{Mass}} = -\frac{GM}{r}$
- Gravitational potential energy,
 $U = \text{Gravitational potential} \times \text{mass} = -\frac{GMm}{r}$
- $E = -\frac{dV}{dr}$
- Total energy of a body in a gravitational field,
 $= \text{K.E.} + \text{P.E.} = \frac{1}{2}mv^2 + \left(-\frac{GMm}{r}\right)$

UNITS USED

Gravitational intensity E is in Nkg^{-1} or ms^{-2} ,
gravitational potential V in J kg^{-1} and gravitational
P.E. in joule.

EXAMPLE 27. Find the intensity of gravitational field when a force of 100 N acts on a body of mass 10 kg in the gravitational field.

Solution. Here $F = 100 \text{ N}$, $m = 10 \text{ kg}$

Intensity of gravitational field,

$$E = \frac{F}{m} = \frac{100 \text{ N}}{10 \text{ kg}} = 10 \text{ Nkg}^{-1}.$$

EXAMPLE 28. Two bodies of masses 10 kg and 1000 kg are at a distance 1 m apart. At which point on the line joining them will the gravitational field intensity be zero?

Solution. Let the resultant gravitational intensity be zero at distance x from the mass of 10 kg on the line joining the centres of the two bodies. At this point, the gravitational intensities due to the two bodies must be equal and opposite.

$$\therefore \frac{G \times 10}{x^2} = \frac{G \times 1000}{(1-x)^2}$$

$$\text{or } 100x^2 = (1-x)^2 \quad \text{or } 10x = 1-x$$

$$\text{or } 11x = 1 \quad \text{or } x = 1/11 \text{ m.}$$

EXAMPLE 29. Two masses, 800 kg and 600 kg, are at a distance 0.25 m apart. Compute the magnitude of the intensity of the gravitational field at a point distant 0.20 m from the 800 kg mass and 0.15 m from the 600 kg mass.

Solution. Let A and B be the positions of the two masses and P the point at which the intensity of the gravitational field is to be computed.

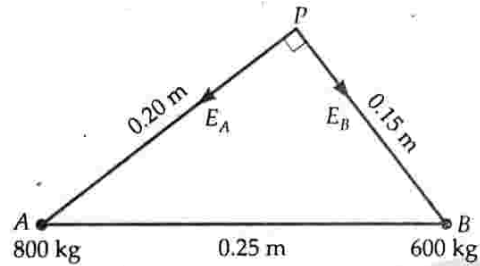

Fig. 8.23

Gravitational intensity at P due to mass at A ,

$$E_A = \frac{GM}{r^2} = G \frac{800}{(0.20)^2} = 20,000 G, \text{ along } PA$$

Gravitational intensity at P due to mass at B ,

$$E_B = G \frac{600}{(0.15)^2} = \frac{80,000}{3} G, \text{ along } PB$$

In $\triangle APB$,

$$PA^2 + PB^2 = AB^2$$

$\therefore \angle APB = 90^\circ$.

Hence the magnitude of resultant gravitational intensity at P is

$$\begin{aligned} E &= \sqrt{E_A^2 + E_B^2} = G \sqrt{(20,000)^2 + \left(\frac{80,000}{3}\right)^2} \\ &= 6.66 \times 10^{-11} \times \frac{10,000}{3} = 2.22 \times 10^{-6} \text{ N.} \end{aligned}$$

EXAMPLE 30. At a point above the surface of the earth, the gravitational potential is $-5.12 \times 10^7 \text{ J kg}^{-1}$ and the acceleration due to gravity is 6.4 ms^{-2} . Assuming the mean radius of the earth to be 6400 km, calculate the height of this point above the earth's surface.

Solution. Let r be the distance of the given point from the centre of the earth. Then

Gravitational potential,

$$V = -\frac{GM}{r} = -5.12 \times 10^7 \text{ J kg}^{-1} \quad \dots(i)$$

Acceleration due to gravity,

$$g = \frac{GM}{r^2} = 6.4 \text{ ms}^{-2} \quad \dots(ii)$$

Dividing (i) by (ii),

$$r = \frac{5.12 \times 10^7}{6.4} = 8 \times 10^6 \text{ m} = 8000 \text{ km}$$

Height of the point from the earth's surface

$$= 8000 - 6400 = 1600 \text{ km.}$$

EXAMPLE 31. The radius of the earth is $6.37 \times 10^6 \text{ m}$, its mean density is $5.5 \times 10^3 \text{ kg m}^{-3}$ and $G = 6.66 \times 10^{-11} \text{ Nm}^2 \text{ kg}^{-2}$. Determine the gravitational potential on the surface of the earth.

Solution. Here $R = 6.37 \times 10^6$ m,

$$\rho = 5.5 \times 10^3 \text{ kg m}^{-3}, \quad G = 6.66 \times 10^{-11} \text{ Nm}^2 \text{ kg}^{-2}$$

Mass of the earth,

$$M = \text{Volume} \times \text{density} = \frac{4}{3} \pi R^3 \rho$$

Gravitational potential on the earth's surface

$$\begin{aligned} V &= -\frac{GM}{R} = -\frac{G}{R} \times \frac{4}{3} \pi R^3 \rho = -\frac{4}{3} \pi GR^2 \rho \\ &= -\frac{4}{3} \times 3.14 \times 6.66 \times 10^{-11} \times (6.37 \times 10^6)^2 \times 5.5 \times 10^3 \\ &= -6.22 \times 10^7 \text{ J kg}^{-1}. \end{aligned}$$

EXAMPLE 32. Three mass points each of mass m are placed at the vertices of an equilateral triangle of side l . What is the gravitational field and potential due to three masses at the centroid of the triangle?

Solution. In Fig. 8.24, three mass points, each of mass m , are placed at three vertices of equilateral ΔABC of side l . If O is the centroid of the triangle, then $OA = OB = OC$.

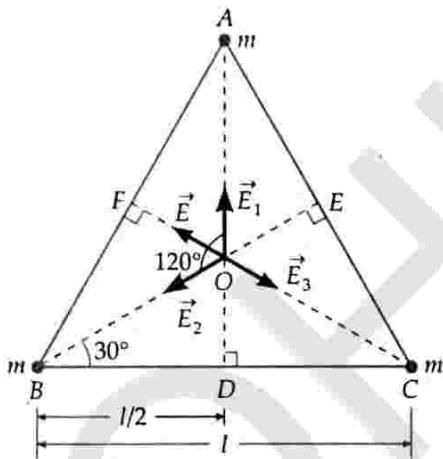

Fig. 8.24

From right ΔODB ,

$$\cos 30^\circ = \frac{BD}{OB} = \frac{l/2}{OB}$$

or
$$OB = \frac{l/2}{\cos 30^\circ} = \frac{l/2}{\sqrt{3}/2} = \frac{l}{\sqrt{3}}$$

Gravitational fields at O due to mass points at A , B and C are as follows :

$$E_1 = \frac{Gm}{(OA)^2} = \frac{Gm}{(l/\sqrt{3})^2} = \frac{3Gm}{l^2}, \text{ along } \vec{OA}$$

$$E_2 = \frac{Gm}{(OB)^2} = \frac{3Gm}{l^2}, \text{ along } \vec{OB}$$

$$E_3 = \frac{Gm}{(OC)^2} = \frac{3Gm}{l^2}, \text{ along } \vec{OC}$$

Angle between \vec{E}_1 and \vec{E}_2 is 120° . Their resultant is

$$\begin{aligned} E &= \sqrt{E_1^2 + E_2^2 + 2E_1 E_2 \cos 120^\circ} \\ &= \frac{3Gm}{l^2} \sqrt{1 + 1 + 2 \times \left(-\frac{1}{2}\right)} = \frac{3Gm}{l^2}, \text{ along } \vec{OF} \end{aligned}$$

Clearly, \vec{E} is equal and opposite to \vec{E}_3 , hence the resultant gravitational field at O is zero.

As gravitational potential is a scalar quantity, so the total gravitational potential at O is

$$\begin{aligned} V &= V_1 + V_2 + V_3 = -\frac{Gm}{OA} - \frac{Gm}{OB} - \frac{Gm}{OC} \\ &= -\frac{3Gm}{OA} = -\frac{3Gm}{l/\sqrt{3}} \quad \left[\because OA = OB = OC = \frac{l}{\sqrt{3}} \right] \end{aligned}$$

or
$$V = -3\sqrt{3} \frac{Gm}{l}$$

EXAMPLE 33. Find the potential energy of a system of four particles, each of mass m , placed at the vertices of a square of side l . Also obtain the potential at the centre of the square.

[NCERT]

Solution. In Fig. 8.25,

$$AB = BC = CD = DA = l$$

$$AC = BD = \sqrt{l^2 + l^2} = \sqrt{2} l$$

$$OA = OB = OC = OD = \sqrt{2} l/2 = l/\sqrt{2}$$

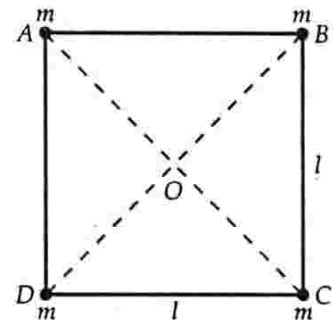

Fig. 8.25

By the principle of superposition, total potential energy of the system of particles is

$$\begin{aligned} U &= U_{BA} + (U_{CB} + U_{CA}) + (U_{DA} + U_{DB} + U_{DC}) \\ &= 4 U_{BA} + 2 U_{DB} \end{aligned}$$

$$\left[\because U_{BA} = U_{DA} = U_{DC} = U_{CB}, U_{CA} = U_{DB} \right]$$

$$= 4 \left(-\frac{Gmm}{l} \right) + 2 \left(-\frac{Gmm}{l/\sqrt{2}} \right)$$

$$= -\frac{2 Gm^2}{l} \left[2 + \frac{1}{\sqrt{2}} \right] = -\frac{2 Gm^2}{l} [2 + 0.707]$$

$$= -\frac{5.41 Gm^2}{l}$$

Total gravitational potential at the centre O ,

$$V = V_A + V_B + V_C + V_D = 4 V_A = 4 \left(-\frac{Gm}{OA} \right)$$

$$= 4 \left(-\frac{Gm}{l/\sqrt{2}} \right) = -\frac{4\sqrt{2} Gm}{l}$$

EXAMPLE 34. Two bodies of masses m_1 and m_2 are placed at a distance r apart. Show that at the position where the gravitational field due to them is zero, the potential is given by

$$V = -\frac{G}{r} [m_1 + m_2 + 2\sqrt{m_1 m_2}] \quad \text{[IIT]}$$

Solution. Let the gravitational field be zero at a point P at distance x from m_1 and $(r-x)$ from m_2 . Then

$$\frac{Gm_1}{x^2} = \frac{Gm_2}{(r-x)^2} \quad \text{or} \quad \frac{\sqrt{m_1}}{x} = \frac{\sqrt{m_2}}{(r-x)}$$

$$\text{or } (r-x)\sqrt{m_1} = x\sqrt{m_2} \quad \text{or } x(\sqrt{m_1} + \sqrt{m_2}) = r\sqrt{m_1}$$

$$\therefore x = \frac{r\sqrt{m_1}}{\sqrt{m_1} + \sqrt{m_2}} \quad \text{or} \quad \frac{1}{x} = \frac{\sqrt{m_1} + \sqrt{m_2}}{r\sqrt{m_1}}$$

$$\text{and } (r-x) = r - \frac{r\sqrt{m_1}}{\sqrt{m_1} + \sqrt{m_2}} = \frac{r\sqrt{m_2}}{\sqrt{m_1} + \sqrt{m_2}}$$

$$\text{or } \frac{1}{r-x} = \frac{\sqrt{m_1} + \sqrt{m_2}}{r\sqrt{m_2}}$$

Gravitational potential at point P due to masses m_1 and m_2 will be

$$V = V_1 + V_2 = -\frac{Gm_1}{x} - \frac{Gm_2}{r-x} = -G \left[\frac{m_1}{x} + \frac{m_2}{r-x} \right]$$

$$= -G \left[\frac{m_1(\sqrt{m_1} + \sqrt{m_2})}{r\sqrt{m_1}} + \frac{m_2(\sqrt{m_1} + \sqrt{m_2})}{r\sqrt{m_2}} \right]$$

$$= -\frac{G}{r} [m_1 + m_2 + 2\sqrt{m_1 m_2}].$$

EXAMPLE 35. A non-homogeneous sphere of radius R has the following density variation :

$$\rho = \rho_0 \quad \text{for } r \leq R/3$$

$$\rho = \rho_0/2 \quad \text{for } R/3 < r \leq 3R/4$$

$$\rho = \rho_0/8 \quad \text{for } 3R/4 < r \leq R.$$

What is the gravitational field due to the sphere at $r = R/4, R/2, 5R/6$ and $2R$?

Solution. The gravitational field due to a spherical body of mass M at a distance r is given by

$$E = \frac{GM}{r^2}$$

(i) For $r = R/4$, density $= \rho_0$

Mass of the spherical portion of radius $R/4$,

$$M = \frac{4}{3} \pi \left(\frac{R}{4} \right)^3 \rho_0$$

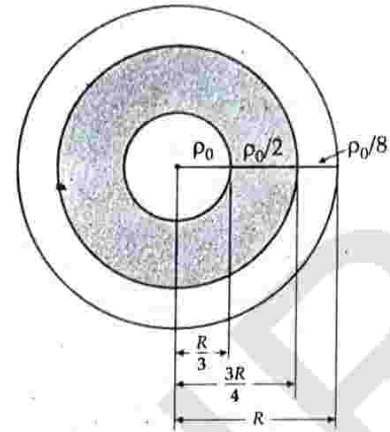

Fig. 8.26

Gravitational field at distance $r = R/4$ from the centre,

$$E_1 = G \times \frac{4}{3} \pi \left(\frac{R}{4} \right)^3 \rho_0 \times \frac{1}{(R/4)^2}$$

$$= 0.33 \pi GR \rho_0.$$

(ii) For $r = R/2$, density of the portion of sphere of radius $R/3$ is ρ_0 and of the portion between $R/3$ and $R/2$, the density is $\rho_0/2$.

\therefore Mass of the spherical portion of radius $R/2$,

$$\therefore M = \frac{4}{3} \pi \left(\frac{R}{3} \right)^3 \rho_0 + \left[\frac{4}{3} \pi \left(\frac{R}{2} \right)^3 - \frac{4}{3} \pi \left(\frac{R}{3} \right)^3 \right] \frac{\rho_0}{2}$$

$$= \frac{4}{3} \pi R^3 \rho_0 \left[\frac{1}{27} + \frac{1}{16} - \frac{1}{54} \right] = 0.108 \pi R^3 \rho_0$$

The gravitational field at the distance $r = R/2$,

$$E_2 = \frac{G \times 0.108 \pi R^3 \rho_0}{(R/2)^2} = 0.43 \pi GR \rho_0.$$

(iii) For $r = 5R/6$, the density of portion of radius $R/3$ is ρ_0 , of the portion between $r = R/3$ to $r = 3R/4$ is $\rho_0/2$ and of the portion between $r = 3R/4$ to $r = 5R/6$ is $\rho_0/8$.

$$\therefore M = \frac{4}{3} \pi \left(\frac{R}{3} \right)^3 \rho_0 + \left[\frac{4}{3} \pi \left(\frac{3R}{4} \right)^3 - \frac{4}{3} \pi \left(\frac{R}{3} \right)^3 \right] \frac{\rho_0}{2}$$

$$+ \left[\frac{4}{3} \pi \left(\frac{5R}{6} \right)^3 - \frac{4}{3} \pi \left(\frac{3R}{4} \right)^3 \right] \frac{\rho_0}{8}$$

$$= \frac{4}{3} \pi R^3 \rho_0 \left[\frac{1}{27} + \frac{27}{128} - \frac{1}{54} + \frac{125}{1728} - \frac{27}{512} \right]$$

$$= 0.332 \pi R^3 \rho_0.$$

The gravitational field at the distance $r = 5R/6$,

$$E_3 = \frac{G \times 0.332 \pi R^3 \rho_0}{(5R/6)^2} = 0.48 G \pi R \rho_0.$$

(iv) For $r = 2R$, the gravitational field is due to the whole of the mass of the sphere.

$$\begin{aligned} \therefore M &= \frac{4}{3} \pi \left(\frac{R}{3}\right)^3 \rho_0 + \left[\frac{4}{3} \pi \left(\frac{3R}{4}\right)^3 - \frac{4}{3} \pi \left(\frac{R}{3}\right)^3 \right] \frac{\rho_0}{2} \\ &\quad + \left[\frac{4}{3} \pi R^3 - \frac{4}{3} \pi \left(\frac{3R}{4}\right)^3 \right] \frac{\rho_0}{8} \\ &= \frac{4}{3} \pi R^3 \rho_0 \left[\frac{1}{27} + \frac{27}{128} - \frac{1}{54} + \frac{1}{8} - \frac{27}{512} \right] \\ &= 0.402 \pi R^3 \rho_0 \end{aligned}$$

The gravitational field at the distance $r = 2R$,

$$E_4 = \frac{G \times 0.402 \pi R^3 \rho_0}{(2R)^2} = 0.1 \pi GR \rho_0.$$

✖ PROBLEMS FOR PRACTICE

1. The gravitational field intensity at a point 10,000 km from the centre of the earth is 4.8 N kg^{-1} . Calculate the gravitational potential at that point.

$$\text{(Ans. } -4.8 \times 10^7 \text{ J kg}^{-1}\text{)}$$

2. The distance between the earth and the moon is 3.85×10^8 metre. At what point in between the two will the gravitational field intensity be zero? Mass of the earth = 6.0×10^{24} kg, mass of the moon = 7.26×10^{22} kg.

$$\text{(Ans. } 3.47 \times 10^8 \text{ m from the centre of the earth)}$$

3. Two bodies of masses 100 kg and 1000 kg are at a distance 1.00 metre apart. Calculate the gravitational field intensity and the potential at the middle-point of the line joining them. Take $G = 6.67 \times 10^{-11} \text{ Nm}^2 \text{ kg}^{-2}$.

$$\text{(Ans. } 2.40 \times 10^{-7} \text{ Nkg}^{-1}, -1.47 \times 10^{-7} \text{ J kg}^{-1}\text{)}$$

4. The mass of the earth is 6.0×10^{24} kg. Calculate (i) the potential energy of a body of mass 33.5 kg and (ii) the gravitational potential, at a distance of 3.35×10^{10} m from the centre of the earth. Take $G = 6.67 \times 10^{-11} \text{ Nm}^2 \text{ kg}^{-2}$.

$$\text{[Ans. (i) } -4.02 \times 10^5 \text{ J (ii) } -12 \times 10^3 \text{ J kg}^{-1}\text{]}$$

5. The radius of the earth is R and the acceleration due to gravity at its surface is g . Calculate the work required in raising a body of mass m to a height h from the surface of the earth.

$$\left(\text{Ans. } \frac{mgh}{1 + \frac{h}{R}} \right)$$

6. Find the work done to bring 4 particles each of mass 100 gram from large distances to the vertices of a square of side 20 cm. (Ans. -1.80×10^{-11} J)

✖ HINTS

1. Gravitational field intensity, $E = \frac{GM}{R^2}$

$$\text{Gravitational potential, } V = -\frac{GM}{R}$$

$$\therefore \frac{V}{E} = R$$

$$\text{or } V = -E \times R = -4.8 \times 10,000 \times 10^3 \\ = -4.8 \times 10^7 \text{ J kg}^{-1}.$$

5. Let M be the mass of the earth. Then

Work done = Change in P.E.

$$= -\frac{GMm}{R+h} - \left[-\frac{GMm}{R} \right]$$

$$= GMm \left[\frac{1}{R} - \frac{1}{R+h} \right]$$

$$= \frac{GMmh}{R(R+h)} = \frac{gR^2 mh}{R(R+h)}$$

$$= \frac{mgh}{1+h/R} \quad [\because GM = gR^2]$$

6. As shown in Fig. 8.27, suppose the four particles are placed at the vertices of A, B, C and D of square $ABCD$. Here $AB = BC = CD = DA = 20 \text{ cm} = 0.2 \text{ m}$

$$AC = BC = \sqrt{(0.2)^2 + (0.2)^2} = 0.2\sqrt{2} \text{ m.}$$

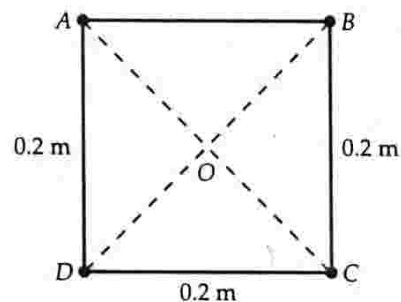

Fig. 8.27

Total work done = Gain in P.E. of the system

$$\text{or } W = U_{BA} + (U_{CB} + U_{CA}) + (U_{DA} + U_{DC} + U_{DB})$$

$$= 4U_{BA} + 2U_{DB}$$

$$[\because U_{BA} = U_{DA} = U_{DC} = U_{CB} \\ \text{and } U_{CA} = U_{DB}]$$

$$= 4 \times \left[-\frac{Gm_1 m_2}{AB} \right] + 2 \times \left[-\frac{Gm_1 m_2}{BD} \right]$$

$$= 4 \times \left[-\frac{6.67 \times 10^{11} \times 0.1 \times 0.1}{0.2} \right]$$

$$+ 2 \times \left[-\frac{6.67 \times 10^{-11} \times 0.1 \times 0.1}{0.2\sqrt{2}} \right]$$

$$= -1.33 \times 10^{-11} - 0.47 \times 10^{11} = -1.80 \times 10^{-11} \text{ J.}$$

8.21 ▼ ESCAPE VELOCITY

36. Define escape velocity. Obtain an expression for the escape velocity of a body from the surface of the earth.

Escape velocity. If we throw a ball into air, it rises to a certain height and falls back. If we throw it with a greater velocity, it rises to a greater height. If we throw it with a sufficient velocity, it will never come back. It will escape from the gravitational pull of the earth. This minimum velocity is called escape velocity.

Escape velocity is the minimum velocity with which a body must be projected vertically upwards in order that it may just escape the gravitational field of the earth.

Expression for escape velocity. Consider the earth to be a sphere of mass M and radius R with centre O . Suppose a body of mass m lies at point P at distance x from its centre, as shown in Fig. 8.28. The gravitational force of attraction on the body at P is

$$F = \frac{GMm}{x^2}$$

The small work done in moving the body through small distance $PQ = dx$ against the gravitational force is given by

$$dW = Fdx = \frac{GMm}{x^2} dx$$

The total work done in moving the body from the surface of the earth ($x = R$) to a region beyond the gravitational field of the earth ($x = \infty$) will be

$$\begin{aligned} W &= \int dW = \int_R^\infty \frac{GMm}{x^2} dx \\ &= GMm \int_R^\infty x^{-2} dx = GMm \left[-\frac{1}{x} \right]_R^\infty \\ &= GMm \left[-\frac{1}{\infty} + \frac{1}{R} \right] = \frac{GMm}{R} \end{aligned}$$

If v_e is the escape velocity of the body, then the kinetic energy $\frac{1}{2}mv_e^2$ imparted to the body at the surface of the earth will be just sufficient to perform work W .

$$\therefore \frac{1}{2}mv_e^2 = \frac{GMm}{R} \quad \text{or} \quad v_e^2 = \frac{2GM}{R}$$

$$\text{Escape velocity} \quad v_e = \sqrt{\frac{2GM}{R}} \quad \dots(i)$$

$$\text{As} \quad g = \frac{GM}{R^2} \quad \text{or} \quad GM = gR^2$$

$$\therefore v_e = \sqrt{\frac{2gR^2}{R}} \quad \text{or} \quad v_e = \sqrt{2gR} \quad \dots(ii)$$

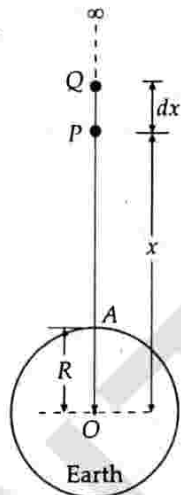

Fig. 8.28

If ρ is the mean density of the earth, then

$$M = \frac{4}{3} \pi R^3 \rho$$

$$\therefore v_e = \sqrt{\frac{2G}{R} \times \frac{4}{3} \pi R^3 \rho} = \sqrt{\frac{8\pi G R^2 \rho}{3}} \quad \dots(iii)$$

Equations (i), (ii) and (iii) give different expressions for the escape velocity of a body. Clearly, the escape velocity does not depend on the mass of the body projected.

▲ For the earth, $g = 9.8 \text{ ms}^{-2}$ and $R = 6.4 \times 10^6 \text{ m}$, so

$$\begin{aligned} v_e &= \sqrt{2gR} = \sqrt{2 \times 9.8 \times 6.4 \times 10^6} \\ &= 11.2 \times 10^3 \text{ ms}^{-1} = 11.2 \text{ kms}^{-1} \end{aligned}$$

- ▲ In deriving the expression for escape velocity, we have neglected the air resistance on the body. In actual practice, the value of escape velocity is slightly greater than the above calculated value.
- ▲ The escape velocity does not depend on angle of projection from the earth's surface. But as the earth rotates about its axis, so it becomes easier to attain escape velocity if the body is projected in the direction in which the launch site is moving.
- ▲ As the escape velocity depends on the mass and radius of the planet from the surface of which the body is projected, so value of escape velocity is different for different planets.
- ▲ Some important escape velocities

Heavenly body	Escape velocity
Moon	2.3 kms^{-1}
Mercury	4.28 kms^{-1}
Earth	11.2 kms^{-1}
Jupiter	60 kms^{-1}
Sun	618 kms^{-1}
Neutron star	$2 \times 10^5 \text{ kms}^{-1}$

- ▲ A planet will have atmosphere if the root mean square velocity of its atmospheric molecules is less than the escape velocity for the given planet. That is why moon has no atmosphere ($v_e = 2.3 \text{ kms}^{-1}$) while Jupiter has a thick atmosphere ($v_e = 60 \text{ kms}^{-1}$). Even the lightest hydrogen cannot escape from its surface.

Examples based on Escape Velocity of a Satellite

FORMULAE USED

$$1. \quad v_e = \sqrt{\frac{2GM}{R}} = \sqrt{2gR} = \sqrt{\frac{8}{3} \pi G \rho R^2}$$

UNITS USED

Velocity v_e is in ms^{-1} , radius R in metre.

EXAMPLE 36. Find the velocity of escape at the earth given that its radius is 6.4×10^6 m and the value of g at its surface is 9.8 ms^{-2} .

Solution. Here $R = 6.4 \times 10^6$ m, $g = 9.8 \text{ ms}^{-2}$

$$v_e = \sqrt{2gR} = \sqrt{2 \times 9.8 \times 6.4 \times 10^6}$$

$$= 11.2 \times 10^3 \text{ ms}^{-1} = 11.2 \text{ kms}^{-1}.$$

EXAMPLE 37. Determine the escape velocity of a body from the moon. Take the moon to be a uniform sphere of radius 1.76×10^6 m, and mass 7.36×10^{22} kg.

Given $G = 6.67 \times 10^{-11} \text{ Nm}^2 \text{ kg}^{-2}$.

Solution. Here $R = 1.76 \times 10^6$ m, $M = 7.36 \times 10^{22}$ kg

$$v_e = \sqrt{\frac{2GM}{R}} = \sqrt{\frac{2 \times 6.67 \times 10^{-11} \times 7.36 \times 10^{22}}{1.76 \times 10^6}}$$

$$= 2375 \text{ ms}^{-1} = 2.375 \text{ km s}^{-1}.$$

EXAMPLE 38. A black hole is a body from whose surface nothing may even escape. What is the condition for a uniform spherical body of mass M to be a black hole? What should be the radius of such a black hole if its mass is nine times the mass of the earth?

[Delhi 03C]

Solution. From Einstein's special theory of relativity, we know that speed of any object cannot exceed the speed of light, $c = 3 \times 10^8 \text{ ms}^{-1}$. Thus c is the upper limit to the projectile's escape velocity. Hence for a body to be a black hole,

$$v_e = \sqrt{\frac{2GM}{R}} \leq c$$

If $M = 9 M_E = 9 \times 6 \times 10^{24}$ kg, then

$$R = \frac{2GM}{c^2} = \frac{2 \times 6.67 \times 10^{-11} \times 9 \times 6 \times 10^{24}}{(3 \times 10^8)^2}$$

$$\approx 8 \times 10^{-2} \text{ m or nearly 8 cm.}$$

EXAMPLE 39. Jupiter has a mass 318 times that of the earth, and its radius is 11.2 times the earth's radius. Estimate the escape velocity of a body from Jupiter's surface, given that the escape velocity from the earth's surface is 11.2 km s^{-1} .

Solution. Escape velocity from the earth's surface is

$$v_e = \sqrt{\frac{2GM}{R}} = 11.2 \text{ kms}^{-1}$$

Escape velocity from Jupiter's surface will be

$$v'_e = \sqrt{\frac{2GM'}{R'}}$$

But $M' = 318 M$, $R' = 11.2 R$

$$\therefore v'_e = \sqrt{\frac{2G(318M)}{11.2R}} = \sqrt{\frac{2GM}{R} \times \frac{318}{11.2}}$$

$$= v_e \times \sqrt{\frac{318}{11.2}} = 11.2 \times \sqrt{\frac{318}{11.2}} = 59.7 \text{ kms}^{-1}.$$

EXAMPLE 40. Show that the moon would depart for ever if its speed were increased by 42%.

Solution. The centripetal force required by the moon to revolve around the earth is provided by gravitational attraction.

$$\therefore \frac{mv_0^2}{R} = \frac{GMm}{R^2}$$

$$\text{or } v_0 = \sqrt{\frac{GM}{R}} = \sqrt{\frac{gR^2}{R}} = \sqrt{gR}$$

Velocity required to escape, $v_e = \sqrt{2gR}$

% increase in the velocity of moon

$$= \frac{v_e - v_0}{v_0} \times 100 = \frac{\sqrt{2gR} - \sqrt{gR}}{\sqrt{gR}} \times 100$$

$$= \frac{\sqrt{2} - 1}{1} \times 100 = (1.414 - 1) \times 100 = 41.4\% \approx 42\%.$$

EXAMPLE 41. Calculate the escape velocity for an atmospheric particle 1600 km above the earth's surface, given that the radius of the earth is 6400 km and acceleration due to gravity on the surface of earth is 9.8 ms^{-2} .

Solution. At a height h above the earth's surface, we have

$$v_e = \sqrt{2g_h(R+h)}, \quad g_h = \frac{gR^2}{(R+h)^2}$$

$$\therefore v_e = \sqrt{\frac{2 \times gR^2}{(R+h)^2} \times (R+h)} = \sqrt{\frac{2gR^2}{R+h}}$$

But $g = 9.8 \text{ ms}^{-2}$, $R = 6.4 \times 10^6$ m,

$h = 1600 \text{ km} = 1.6 \times 10^6$ m,

$R+h = (6.4 + 1.6) \times 10^6 = 8 \times 10^6$ m

$$\therefore v_e = \sqrt{\frac{2 \times 9.8 \times (6.4 \times 10^6)^2}{8 \times 10^6}}$$

$$= 10.02 \times 10^3 \text{ ms}^{-1} = 10.02 \text{ kms}^{-1}.$$

EXAMPLE 42. The radius of a planet is double that of the earth but their average densities are the same. If the escape velocities at the planet and at the earth are v_p and v_E respectively, then prove that $v_p = 2 v_E$.

Solution. If ρ is the average density of the earth, then mass of the earth,

$$M_E = \frac{4}{3} \pi R_E^3 \rho$$

Escape velocity on the earth,

$$v_E = \sqrt{\frac{2GM_E}{R_E}} = \sqrt{\frac{2G}{R_E} \times \frac{4}{3} \pi R_E^3 \rho}$$

$$= R_E \sqrt{\frac{8}{3} G \pi \rho}$$

Similarly, escape velocity on the planet,

$$v_p = R_p \sqrt{\frac{8}{3} G \pi \rho}$$

$$\therefore \frac{v_p}{v_E} = \frac{R_p}{R_E}$$

But $R_p = 2 R_E \therefore v_p = 2 v_E$.

Example 43. Two uniform solid spheres of equal radii R , but mass M and $4M$ have a centre to centre separation $6R$, as shown in Fig. 8.29. The two spheres are held fixed. A projectile of mass m is projected from the surface of the sphere of mass M directly towards the centre of the second sphere. Obtain an expression for the minimum speed v of the projectile so that it reaches the surface of the second sphere.

[NCERT]

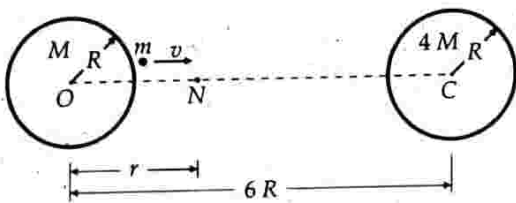

Fig. 8.29

Solution. The two spheres exert gravitational forces on the projectile in mutually opposite directions. At the neutral point N , these two forces cancel each other. If $ON = r$, then

$$\frac{GMm}{r^2} = \frac{G(4M)m}{(6R-r)^2}$$

or $(6R-r)^2 = 4r^2$ or $6R-r = \pm 2r$
or $r = 2R$ or $-6R$

The neutral point $r = -6R$ is inadmissible.

$$\therefore ON = r = 2R$$

It will be sufficient to project the particle m with a minimum speed v which enables it to reach the point N . Thereafter, the particle m gets attracted by the gravitational pull of $4M$.

The total mechanical energy of m at surface of left sphere is

$$E_i = \text{K.E. of } m + \text{P.E. due to left sphere} + \text{P.E. due to right sphere}$$

$$= \frac{1}{2} mv^2 - \frac{GMm}{R} - \frac{4GMm}{5R}$$

At the neutral point, speed of the particle becomes zero. The energy is purely potential.

$$\begin{aligned} \therefore E_N &= \text{P.E. due to left sphere} \\ &\quad + \text{P.E. due to right sphere} \\ &= -\frac{GMm}{2R} - \frac{4GMm}{4R} \end{aligned}$$

By conservation of mechanical energy,

$$E_i = E_N$$

$$\text{or } \frac{1}{2} mv^2 - \frac{GMm}{R} - \frac{4GMm}{5R} = -\frac{GMm}{2R} - \frac{4GMm}{4R}$$

$$\text{or } v^2 = \frac{2GM}{R} \left(\frac{4}{5} - \frac{1}{2} \right) = \frac{3GM}{5R}$$

$$\therefore v = \sqrt{\frac{3GM}{5R}}$$

✖ PROBLEMS FOR PRACTICE

- Find the velocity of escape at the moon. Given that its radius is 1.7×10^6 m and the value of 'g' is 1.63 ms^{-2} . (Ans. 2.354 kms^{-1})
- The mass of Jupiter is 1.91×10^{36} kg and its diameter is 13.1×10^7 m. Calculate the escape velocity on the surface of Jupiter. (Ans. $1.972 \times 10^9 \text{ ms}^{-1}$)
- If earth has a mass 9 times and radius twice that of a planet Mars, calculate the minimum velocity required by a rocket to pull out of gravitational force of Mars. Take the escape velocity on the surface of earth to be 11.2 kms^{-1} . [Chandigarh 04 ; Himachal 09] (Ans. 5.28 kms^{-1})
- The escape velocity of a projectile on the surface of the earth is 11.2 kms^{-1} . A body is projected out with twice this speed. What is the speed of the body far away from the earth i.e. at infinity? Ignore the presence of the sun and other planets, etc. (Ans. 19.4 kms^{-1})
- Find the velocity of escape from the sun, if its mass is 1.89×10^{30} kg and its distance from the earth is 1.59×10^8 km. Take $G = 6.67 \times 10^{-11} \text{ Nm}^2 \text{ kg}^{-2}$. (Ans. $3.98 \times 10^4 \text{ ms}^{-1}$)
- A body is at a height equal to the radius of the earth from the surface of the earth. With what velocity be it thrown so that it goes out of the gravitational field of the earth? Given $M_e = 6.0 \times 10^{24}$ kg, $R_e = 6.4 \times 10^6$ m and $G = 6.67 \times 10^{-11} \text{ Nm}^2 \text{ kg}^{-2}$. (Ans. 7.9 kms^{-1})
- A body of mass 100 kg falls on the earth from infinity. What will be its velocity on reaching the earth? What will be its K.E.? Radius of the earth is 6400 km and $g = 9.8 \text{ ms}^{-2}$. Air friction is negligible. (Ans. 11.2 kms^{-1} , $6.27 \times 10^9 \text{ J}$)

✖ HINTS

3. For earth, $v_e = \sqrt{\frac{2GM}{R}}$

For Mars, $v'_e = \sqrt{\frac{2GM'}{R'}}$

$$\therefore \frac{v'_c}{v_c} = \sqrt{\frac{M'}{M} \times \frac{R}{R'}} = \sqrt{\frac{1}{9} \times \frac{2}{1}} = \frac{\sqrt{2}}{3}$$

$$\text{or } v'_c = \frac{\sqrt{2}}{3} \times v_c = \frac{1.414 \times 11.2}{3} = 5.28 \text{ kms}^{-1}.$$

$$5. v_c = \sqrt{\frac{2GM}{R}} = \sqrt{\frac{2 \times 6.67 \times 10^{-11} \times 1.89 \times 10^{30}}{1.59 \times 10^{11}}} \\ = 3.98 \times 10^4 \text{ ms}^{-1}.$$

6. Escape velocity from earth's surface,

$$v_c = \sqrt{\frac{2GM_e}{R_e}}$$

If the body is at a height R_e from the earth's surface, then the distance of the body from the centre of the earth will be $2R_e$. Hence in this case, the escape velocity of the body will be

$$v'_c = \sqrt{\frac{2GM_e}{2R_e}} = \sqrt{\frac{2 \times 6.67 \times 10^{-11} \times 6.0 \times 10^{24}}{2 \times 6.4 \times 10^6}} \\ = 7.9 \times 10^3 \text{ ms}^{-1} = 7.9 \text{ kms}^{-1}.$$

7. A body thrown up with escape velocity v_c reaches infinity. Hence a body falling on the earth from infinity should come back with velocity v_c given by

$$v_c = \sqrt{2gR_e} = \sqrt{2 \times 9.8 \times 6400 \times 10^3} \\ = 11.2 \times 10^3 \text{ ms}^{-1} = 11.2 \text{ kms}^{-1}.$$

$$\text{K.E.} = \frac{1}{2} mv_c^2 = \frac{1}{2} \times 100 \times (11.2 \times 10^3)^2 \\ = 6.27 \times 10^9 \text{ J.}$$

8.22 NATURAL AND ARTIFICIAL SATELLITES

37. What is a satellite ?

Satellite. A satellite is a body which continuously revolves on its own around a much larger body in a stable orbit.

38. What are natural and artificial satellites ? Give examples.

Natural satellite. A satellite created by nature is called a natural satellite. Moon is a natural satellite of the earth which, in turn, is a satellite of the sun. In fact, each planet is a satellite of the sun. The planets Jupiter and Saturn have fourteen and twelve satellites respectively.

Artificial satellite. A man made satellite is called an artificial satellite. Russians were the first to put an artificial satellite, SPUTNIK-I, in an orbit around the earth on October 4, 1957. Since then, many artificial satellites have been put into orbits around the earth to study various phenomena in the outer regions of the earth's atmosphere. India entered space age on April 19, 1975 by putting in orbit its first satellite Aryabhata from Russian soil. India's list includes important satellites like INSAT-IA, INSAT-IB, INSAT-2B, IRS-IC, INSAT-2D etc.

8.23 LAUNCHING OF A SATELLITE

39. What is the principle of launching an artificial satellite ?

Ans. Principle of a launching a satellite. Consider a high tower with its top projecting outside the earth's atmosphere. Let us throw a body horizontally from the top of the tower with different velocities. When the velocity is low, the body describes a parabolic path under the effect of gravity and hits the earth's surface at A. With somewhat larger velocity, its path is still parabolic but hits the surface at B covering a larger horizontal range. As we go on increasing the velocity of horizontal projection, the body will hit the ground at a point farther and farther from the foot of the tower. At a certain horizontal velocity, the body will not hit the earth, but will always be in a state of free fall under gravity and attempt to fall to the earth but missing it all the time. Then the body will follow a stable circular path around the earth and will become a satellite of the earth. This horizontal velocity is called orbital velocity.

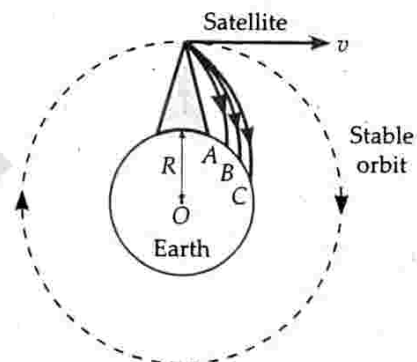

Fig. 8.30 Launching of a satellite.

Hence to put a satellite into an orbit around the earth, we need to give it *two* velocities :

1. A minimum vertical velocity (escape velocity) to take the satellite to a suitable height.
2. After the satellite has ascended the required height, it is given a suitable horizontal velocity to make it move in a circular orbit around the earth.

40. Explain the use of multistage rockets in launching a satellite.

Use of multistage rockets. Escape velocity on the earth's surface is 11.2 kms^{-1} . At this high velocity, the air resistance is very large. Still much higher escape velocities are required to take the satellite to a suitable height. Such high velocities can be imparted to the satellites by using multistage rockets. Generally 3-stage rockets are used. The satellite is placed on the third

stage. At lift off, the exhaust gases build up a very large upthrust so that the rocket accelerates upwards. The rocket rises vertically through the denser atmosphere with a minimum time. When the fuel of the first stage gets exhausted, its casing is detached. Now the rocket is tilted gradually, the second stage comes into operation and its velocity increases further. The second stage gets detached. The final stage of the rocket turns the satellite in a horizontal direction and gives it a proper speed. With this speed, the satellite moves around the earth in a stable orbit.

8.24 ▽ ORBITAL VELOCITY

41. Define orbital velocity of a satellite. Derive expressions for the orbital velocity of a satellite. Show that the escape velocity of a body from the earth's surface is $\sqrt{2}$ times its velocity in a circular orbit just above the earth's surface.

Orbital velocity. Orbital velocity is the velocity required to put the satellite into its orbit around the earth

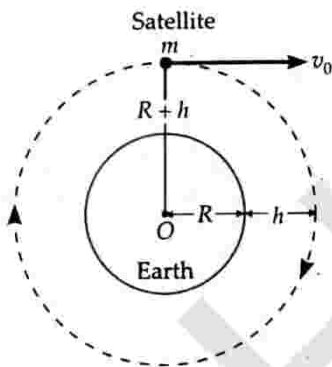

Fig. 8.31 Orbital velocity.

Expression for orbital velocity. In Fig. 8.31, let

M = mass of the earth,

R = radius of the earth,

m = mass of the satellite

v_0 = orbital velocity of the satellite

h = height of the satellite above the earth's surface

$R + h$ = orbital radius of the satellite

According to the law of gravitation, the force of gravity on the satellite is

$$F = \frac{GMm}{(R+h)^2}$$

The centripetal force required by the satellite to keep it in its orbit is

$$F = \frac{mv_0^2}{R+h}$$

In equilibrium, the centripetal force is just provided by the gravitational pull of the earth, so

$$\frac{mv_0^2}{R+h} = \frac{GMm}{(R+h)^2}$$

or
$$v_0^2 = \frac{GM}{R+h}$$

\therefore Orbital velocity,
$$v_0 = \sqrt{\frac{GM}{R+h}} \quad \dots(i)$$

If g is the acceleration due to gravity on the earth's surface, then

$$g = \frac{GM}{R^2}$$

or
$$GM = gR^2$$

Hence
$$v_0 = \sqrt{\frac{gR^2}{R+h}} = R \sqrt{\frac{g}{R+h}}$$

When the satellite revolves close to the surface of the earth, $h = 0$ and the orbital velocity will become

$$v_0 = \sqrt{gR}$$

As $g = 9.8 \text{ ms}^{-2}$ and $R = 6.4 \times 10^6 \text{ m}$, so

$$\begin{aligned} v_0 &= \sqrt{9.8 \times 6.4 \times 10^6} = 7.92 \times 10^3 \text{ ms}^{-1} \\ &= 7.92 \text{ kms}^{-1}. \end{aligned}$$

Some important points

From equation (i), it is clear that the orbital velocity of a satellite

- (i) is independent of the mass of the satellite.
- (ii) decreases with the increase in the radius of the orbit and with increase in the height of the satellite.
- (iii) depends on the mass and radius of the planet about which the satellite revolves.

Relation between orbital velocity and escape velocity. The escape velocity of a body from the earth's surface is

$$v_e = \sqrt{2gR}$$

The orbital velocity of a satellite revolving close to the earth's surface is

$$v_0 = \sqrt{gR}$$

$$\therefore \frac{v_e}{v_0} = \frac{\sqrt{2gR}}{\sqrt{gR}} = \sqrt{2}$$

or
$$v_e = \sqrt{2}v_0.$$

Hence the escape velocity of a body from the earth's surface is $\sqrt{2}$ times its velocity in a circular orbit just above the earth's surface.

42. Derive expressions for time period, height and angular momentum of a satellite.

Time period of a satellite. It is the time taken by a satellite to complete one revolution around the earth. It is given by

$$T = \frac{\text{Circumference of the orbit}}{\text{Orbital velocity}} = \frac{2\pi(R+h)}{v_0}$$

As orbital velocity,

$$v_0 = \sqrt{\frac{GM}{R+h}}$$

$$\therefore T = \frac{2\pi(R+h)}{\sqrt{\frac{GM}{R+h}}} = 2\pi \sqrt{\frac{(R+h)^3}{GM}}$$

But $g = GM/R^2$ or $GM = gR^2$, therefore

$$T = 2\pi \sqrt{\frac{(R+h)^3}{gR^2}} \quad \dots(i)$$

If the earth is a sphere of mean density ρ , then its mass would be

$$M = \text{Volume} \times \text{density} = \frac{4}{3}\pi R^3 \rho$$

$$\therefore T = 2\pi \sqrt{\frac{(R+h)^3}{G \cdot \frac{4}{3}\pi R^3 \rho}} = \sqrt{\frac{3\pi(R+h)^3}{G\rho R^3}}$$

When the satellite revolves close to the earth, $h=0$ and the time period will be

$$T = 2\pi \sqrt{\frac{R^3}{GM}} = 2\pi \sqrt{\frac{R}{g}} = \sqrt{\frac{3\pi}{G\rho}}$$

Putting $g = 9.8 \text{ ms}^{-2}$ and $R = 6.4 \times 10^6 \text{ m}$, we get

$$T = 2\pi \sqrt{\frac{6.4 \times 10^6}{9.8}} = 5078 \text{ s} = \mathbf{84.6 \text{ min.}}$$

Height of a satellite above the earth's surface.

Squaring both sides of equation (i), we get

$$T^2 = \frac{4\pi^2(R+h)^3}{gR^2}$$

$$\text{or } (R+h)^3 = \frac{T^2 R^2 g}{4\pi^2} \quad \text{or } R+h = \left[\frac{T^2 R^2 g}{4\pi^2} \right]^{1/3}$$

$$\therefore \text{Height of satellite, } h = \left[\frac{T^2 R^2 g}{4\pi^2} \right]^{1/3} - R$$

Angular momentum. The angular momentum of a satellite of mass m moving with velocity v_0 in an orbit of radius $r (= R+h)$ is given by

$$L = mv_0 r = m \sqrt{\frac{GM}{r}} r = \sqrt{GMm^2 r}$$

Examples based on Orbital Velocity of Satellites

FORMULAE USED

1. Orbital velocity at a height h ,

$$v_0 = \sqrt{\frac{GM}{R+h}} = \sqrt{\frac{gR^2}{R+h}} = R \sqrt{\frac{g}{R+h}}$$

2. When a satellite revolves close to earth's surface

$$v_0 = \sqrt{gR}$$

$$v_e = \sqrt{2} v_0$$

3. Time period of a satellite

$$T = \frac{2\pi(R+h)}{v_0} = 2\pi \sqrt{\frac{(R+h)^3}{GM}} = \frac{2\pi}{R} \sqrt{\frac{(R+h)^3}{g}}$$

$$= \sqrt{\frac{3\pi(R+h)^3}{G\rho R^3}}$$

4. Height of a satellite, $h = \left[\frac{T^2 R^2 g}{4\pi^2} \right]^{1/3} - R$

UNITS USED

Velocities v_0 and v_e are in ms^{-1} , R and h in metre.

EXAMPLE 44. An artificial satellite revolves around the earth at a height of 1000 km. The radius of the earth is $6.38 \times 10^3 \text{ km}$. Mass of the earth is $6 \times 10^{24} \text{ kg}$ and $G = 6.67 \times 10^{-11} \text{ Nm}^2 \text{ kg}^{-2}$. Find its orbital velocity and period of revolution.

Solution. Here : $h = 1000 \text{ km} = 10^6 \text{ m}$,

$$R = 6.38 \times 10^3 \text{ km} = 6.38 \times 10^6 \text{ m}$$

$$\therefore R+h = 7.38 \times 10^6 \text{ m}, \quad M = 6 \times 10^{24} \text{ kg}$$

Orbital velocity,

$$v_0 = \sqrt{\frac{GM}{R+h}} = \sqrt{\frac{6.67 \times 10^{-11} \times 6 \times 10^{24}}{7.38 \times 10^6}}$$

$$= \mathbf{7364 \text{ ms}^{-1}}.$$

Period of revolution,

$$T = \frac{2\pi(R+h)}{v_0} = \frac{2\pi \times 7.38 \times 10^6}{7364} = \mathbf{6297 \text{ s.}}$$

EXAMPLE 45. A remote sensing satellite of the earth revolves in a circular orbit at a height of 250 km above the earth's surface. What is the (i) orbital speed and (ii) period of revolution of the satellite? Radius of the earth, $R = 6.38 \times 10^6 \text{ m}$, and acceleration due to gravity on the surface of the earth, $g = 9.8 \text{ ms}^{-2}$.

Solution. (i) Here $g = 9.8 \text{ ms}^{-2}$,

$$R = 6.38 \times 10^6 \text{ m}, \quad h = 250,000 \text{ m}$$

$$R+h = 6.38 \times 10^6 + 250,000 = 6.63 \times 10^6 \text{ m}$$

The orbital speed is given by

$$v_0 = \sqrt{\frac{gR^2}{R+h}} = \sqrt{\frac{9.8 \times (6.38 \times 10^6)^2}{6.63 \times 10^6}}$$

$$= 7.76 \times 10^3 \text{ ms}^{-1} = 7.76 \text{ kms}^{-1}.$$

(ii) The period of revolution of the satellite will be

$$T = \frac{2\pi(R+h)}{v_0} = \frac{2 \times 22 \times 6.63 \times 10^6}{7 \times 7.76 \times 10^3}$$

$$= 5370 \text{ s}.$$

EXAMPLE 46. An artificial satellite is going round the earth, close to its surface. What is the time taken by it to complete one round? Given radius of the earth = 6400 km.

Solution. Here $R = 6400 \text{ km} = 6.4 \times 10^6 \text{ m}$,
 $g = 9.8 \text{ ms}^{-2}$

Orbital velocity near the earth's surface is

$$v_0 = \sqrt{gR} = \sqrt{9.8 \times 6.4 \times 10^6} = 7290 \text{ ms}^{-1} \quad \text{or}$$

Time period,

$$T = \frac{2\pi R}{v_0} = \frac{2 \times 22 \times 6.4 \times 10^6}{7 \times 7290} = 5079 \text{ s}$$

$$= 1.411 \text{ hour}.$$

EXAMPLE 47. A satellite revolves in an orbit close to the surface of a planet of mean density $5.51 \times 10^3 \text{ kgm}^{-3}$. Calculate the time period of the satellite.

Given $G = 6.67 \times 10^{-11} \text{ Nm}^2 \text{ kg}^{-2}$.

Solution. Here $\rho = 5.51 \times 10^3 \text{ kgm}^{-3}$,
 $G = 6.67 \times 10^{-11} \text{ Nm}^2 \text{ kg}^{-2}$.

Time period of the satellite near the surface of the planet ($h = 0$) is

$$T = \sqrt{\frac{3\pi}{G\rho}}$$

$$= \sqrt{\frac{3 \times 3.14}{6.67 \times 10^{-11} \times 5.51 \times 10^3}} = 5062.7 \text{ s}.$$

EXAMPLE 48. An earth's satellite makes a circle around the earth in 90 minutes. Calculate the height of the satellite above the earth's surface. Given radius of the earth is 6400 km and $g = 980 \text{ cms}^{-2}$.

Solution. Here $T = 90 \text{ minutes} = 5400 \text{ s}$,

$$R = 6400 \text{ km} = 6.4 \times 10^6 \text{ m}$$

$$g = 980 \text{ cms}^{-2} = 9.8 \text{ ms}^{-2}$$

$$\text{As } T = 2\pi \sqrt{\frac{(R+h)^3}{gR^2}}$$

$$\therefore R+h = \left[\frac{gR^2 T^2}{4\pi^2} \right]^{1/3}$$

$$= \left[\frac{9.8 \times (6.4 \times 10^6)^2 \times (5400)^2}{4 \times 9.87} \right]^{1/3}$$

$$= 6.668 \times 10^6 \text{ m} = 6668 \text{ km}$$

Hence $h = 6668 - R = 6668 - 6400 = 268 \text{ km}$.

EXAMPLE 49. If the period of revolution of an artificial satellite just above the earth's surface be T and the density of earth be ρ , then prove that ρT^2 is a universal constant. Also calculate the value of this constant.

Given : $G = 6.67 \times 10^{-11} \text{ m}^3 \text{ kg}^{-1} \text{ s}^{-2}$.

Solution. As $T = 2\pi \sqrt{\frac{(R+h)^3}{GM}}$

$$\therefore T^2 = \frac{4\pi^2 (R+h)^3}{GM}$$

$$M = \frac{4\pi^2 (R+h)^3}{GT^2}$$

For the satellite revolving just above the earth's surface, $h = 0$. So

$$M = \frac{4\pi^2 R^3}{GT^2}$$

Also, $M = \frac{4}{3} \pi R^3 \rho$

$$\therefore \frac{4}{3} \pi R^3 \rho = \frac{4\pi^2 R^3}{GT^2}$$

$\therefore \rho T^2 = \frac{3\pi}{G}$, which is a universal constant.

$$\text{and } \rho T^2 = \frac{3 \times 3.14}{6.67 \times 10^{-11} \text{ m}^3 \text{ kg}^{-1} \text{ s}^{-2}}$$

$$= 1.41 \times 10^{11} \text{ kgs}^2 \text{ m}^{-3}.$$

EXAMPLE 50. In a two-stage launch of a satellite, the first stage brings the satellite to a height of 150 km and the second stage gives it the necessary critical speed to put it in a circular orbit around the Earth. Which stage requires more expenditure of fuel? (Neglect damping due to air resistance, especially in the first stage).

Mass of the Earth = $6.0 \times 10^{24} \text{ kg}$, radius = 6400 km,
 $G = 6.67 \times 10^{-11} \text{ Nm}^2 \text{ kg}^{-2}$.

Solution. Work done on the satellite in first stage,

$$W_1 = \text{P.E. at height of 150 km}$$

$$- \text{P.E. at the surface of the earth}$$

$$= -\frac{GMm}{R+h} - \left(-\frac{GMm}{R} \right)$$

$$= GMm \left(\frac{1}{R} - \frac{1}{R+h} \right) = \frac{GMmh}{R(R+h)}$$

Work done on the satellite in second stage,

W_2 = Energy required to give it orbital velocity v_0

$$= \frac{1}{2} m v_0^2 = \frac{1}{2} m \left(\frac{GM}{R+h} \right) = \frac{1}{2} \left(\frac{GMm}{R+h} \right)$$

$$\therefore \frac{W_1}{W_2} = \frac{2h}{R} = \frac{2 \times 150}{6400} = \frac{3}{64} < 1.$$

As $W_2 > W_1$, so the second stage requires more expenditure of fuel.

✖ PROBLEMS FOR PRACTICE

- An artificial satellite circled around the earth at a distance of 3400 km. Calculate its orbital velocity and period of revolution. Radius of earth = 6400 km and $g = 9.8 \text{ ms}^{-2}$. (Ans. 6400 ms^{-1} , 9621 s)
- The orbit of a geostationary satellite is concentric and coplanar with the equator of earth and rotates along the direction of rotation of earth. Calculate the height and speed. Take mass of earth = $5.98 \times 10^{27} \text{ g}$ and its radius = 6400 km. Given, $\pi^2 = 9.87$. (Ans. 35850 km, 3.071 kms^{-1})
- A satellite revolves round a planet in an orbit just above the surface of planet. Taking $G = 6.67 \times 10^{-11} \text{ Nm}^2 \text{ kg}^{-2}$ and the mean density of the planet = $8.0 \times 10^3 \text{ kg m}^{-3}$, find the period of satellite. [Ans. 4206.7 s]
- An artificial satellite of mass 100 kg is in a circular orbit of 500 km above the earth's surface. Take radius of earth as $6.5 \times 10^6 \text{ m}$. (i) Find the acceleration due to gravity at any point along the satellite path. (ii) What is the centripetal acceleration of the satellite? Take $g = 9.8 \text{ ms}^{-2}$. [Ans. (i) 8.45 ms^{-2} (ii) 8.45 ms^{-2}]
- A space-ship is launched into a circular orbit close to the earth's surface. What additional velocity has now to be imparted to the space-ship in the orbit to overcome the gravitational pull? (Radius of the earth = 6400 km, $g = 9.8 \text{ ms}^{-2}$). [Roorkee 88] (Ans. 3.278 kms^{-1})

✖ HINTS

$$1. v_0 = R \sqrt{\frac{g}{R+h}} = 64 \times 10^5 \sqrt{\frac{9.8}{(64+34) \times 10^5}} = 6400 \text{ ms}^{-1}$$

$$T = \frac{2\pi(R+h)}{v_0} = \frac{2\pi \times 98 \times 10^5}{6400} = 9621 \text{ s.}$$

- Here $T = 24 \times 3600 \text{ s}$, $G = 6.67 \times 10^{-11} \text{ Nm}^2 \text{ kg}^{-2}$,
 $M = 5.98 \times 10^{27} \text{ g} = 5.98 \times 10^{24} \text{ kg}$
 $R = 6400 \text{ km}$

$$R+h = \left[\frac{T^2 GM}{4\pi^2} \right]^{1/3}$$

$$= \left[\frac{(24 \times 3600)^2 \times 6.67 \times 10^{-11} \times 5.98 \times 10^{24}}{4 \times 9.87} \right]^{1/3}$$

$$= 4.225 \times 10^7 \text{ m} = 42250 \text{ km}$$

$$\therefore h = 42250 - 6400 = 35850 \text{ km}$$

Orbital speed,

$$v_0 = \frac{2\pi(R+h)}{T} = \frac{2 \times 3.14 \times 42250}{24 \times 3600} = 3.071 \text{ kms}^{-1}.$$

- Here $h = 500 \text{ km} = 0.5 \times 10^6 \text{ m}$, $R = 6.5 \times 10^6 \text{ m}$;
 $\therefore R+h = 7.0 \times 10^6 \text{ m}$
 (i) $g' = g \left(\frac{R}{R+h} \right)^2 = 9.8 \left(\frac{6.5 \times 10^6}{7.0 \times 10^6} \right)^2 = 8.45 \text{ ms}^{-2}$.
 (ii) $a_c = \frac{v_0^2}{R+h} = \frac{1}{R+h} \times \frac{gR^2}{R+h} = 8.45 \text{ ms}^{-2}$.
- Orbital velocity near earth's surface, $v_0 = \sqrt{gR_e}$
 Escape velocity, $v_e = \sqrt{2gR_e} = 1.414 \sqrt{gR_e}$
 Additional velocity required
 $= v_e - v_0 = (1.414 - 1) \sqrt{gR_e}$
 $= 0.414 \times \sqrt{9.8 \times 6400 \times 10^3} = 3.278 \times 10^3 \text{ ms}^{-1}$
 $= 3.278 \text{ kms}^{-1}$

8.25 ▼ GEOSTATIONARY SATELLITES

43. What are geostationary satellites? Calculate the height of the orbit above the surface of the earth in which a satellite, if placed, will appear stationary.

Geostationary satellite. If a satellite is made to revolve from west to east with a period of revolution equal to 24 hours in a circular orbit concentric and coplanar with the equatorial plane of the earth, its relative velocity with respect to the earth will be zero. Such a satellite is called *geostationary satellite* because it appears stationary to an observer on the earth. It is called **synchronous satellite** because its angular speed is same as that of the earth about its own axis. When such a satellite is used for communication purposes, it is known as *communication satellite*. Telstar was the first communication satellite sent by U.S.A. into space in 1962.

A satellite which revolves around the earth in its equatorial plane with the same angular speed and in the same direction as the earth rotates about its own axis is called a *geostationary or synchronous satellite*.

Height of a geostationary satellite. The height of a satellite above the earth's surface is given by

$$h = \left[\frac{T^2 R^2 g}{4\pi^2} \right]^{1/3} - R$$

But $T = 24 \text{ h} = 86400 \text{ s}$,

$R = \text{radius of the earth} = 6400 \text{ km}$,

$g = 9.8 \text{ ms}^{-2} = 0.0098 \text{ kms}^{-2}$

$$\therefore h = \left[\frac{(86400)^2 \times (6400)^2 \times 0.0098}{4 \times 9.87} \right]^{1/3} - 6400$$

$$= 42330 - 6400 = 35930 \text{ km.}$$

44. State the necessary conditions for a satellite to be geostationary.

Necessary conditions for a geostationary satellite.

These are as follows :

1. It should revolve in an orbit concentric and coplanar with the equatorial plane of the earth.
2. Its sense of rotation should be same as that of the earth *i.e.*, from west to east.
3. Its period of revolution around the earth should be exactly same as that of the earth about its own axis *i.e.*, 24 hours.
4. It should revolve at a height of nearly 36,000 km above the earth's surface.

45. Discuss the use of geostationary satellites in global communication.

Use of geostationary satellites in global transmission. A satellite cannot establish communication link over the entire earth. This is because, the curvature of the earth keeps a large part of the earth out of sight. However, three uniformly spaced satellites (120° apart from each other) placed in a geostationary orbit and equipped with radio transponders can be used to provide line of sight communication between any two points on the earth, as shown in Fig. 8.32.

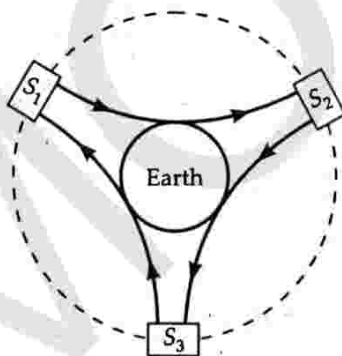

Fig. 8.32 Three uniformly spaced satellites placed in a geostationary orbit.

Such satellites are called synchronous communication satellites (SYNCOMS). The geostationary orbit is also called *Clarke geosynchronous orbit* or *Clarke arc* after the name of famous science writer Arthur C. Clarke who first proposed the idea of a communication satellite in 1945.

46. Give some uses of geostationary satellites.

Uses of geostationary satellites :

1. In communicating radio, T.V. and telephone signals across the world. Geostationary satellites act as reflectors of such signals.
2. In studying upper regions of the atmosphere.
3. In forecasting weather.
4. In determining the exact shape and dimensions of the earth.
5. In studying meteorites.
6. In studying solar radiations and cosmic rays.

EXAMPLE 51. To what latitude does the SYNCOMS coverage extend? What is the orbital speed of a SYNCOMS?

[NCERT]

Solution. Clearly, the latitude of the coverage extends upto the tangent SP , as shown in Fig. 8.33. From right $\triangle OPS$,

$$\cos \lambda = \frac{OP}{OS} = \frac{R_E}{OS} = \frac{6.37 \times 10^3 \text{ km}}{4.22 \times 10^4 \text{ km}} = 0.151.$$

$$\therefore \lambda = 81.3^\circ.$$

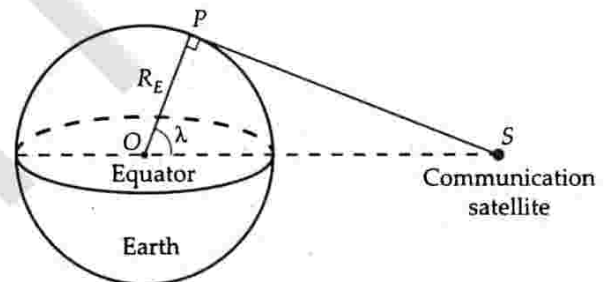

Fig. 8.33

Thus a circular arc of about 90° is left uncovered around the pole. That is why we need three satellites to cover the entire earth.

Orbital speed of the SYNCOMS

$$v = \frac{2\pi r}{T} = \frac{2 \times 3.14 \times 4.22 \times 10^7 \text{ m}}{86400 \text{ s}} = 3067 \text{ ms}^{-1}.$$

8.26 ▼ POLAR SATELLITES

47. What are polar satellites? Give some of their uses.

Polar satellite. A satellite that revolves in a polar orbit is called a polar satellite. A polar orbit is one whose plane is perpendicular to the equatorial plane of the earth. A polar orbit passes over north and south poles of the earth and has a smaller radius of 500 – 800 km. As the earth rotates about its axis, the polar satellite successively passes across the different parts of earth's surface. Thus the polar satellite eventually scans the

entire surface of the earth. Examples of polar satellites are European SPOT and the Indian Earth resources satellites (IERS).

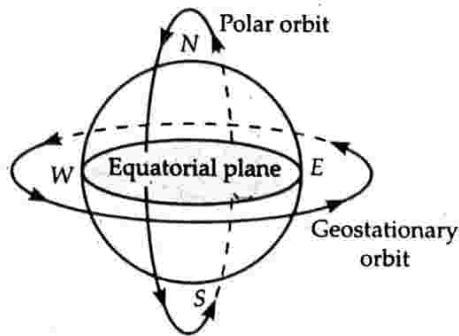

Fig. 8.34 Polar and geostationary orbits.

Uses of polar satellites :

- Polar satellites are used in weather and environment monitoring. They provide more reliable information than geostationary satellites because their orbits are closed to the earth.
- They are used in spying work for military purposes.
- British polar satellite first detected hole in the ozone layer.
- They are used to study topography of Moon, Venus and Mars.

8.27 ▼ TOTAL ENERGY AND BINDING ENERGY OF A SATELLITE

48. Derive an expression for the total energy of a satellite orbiting the earth. What is the significance of negative total energy ?

Total energy of a satellite. Consider a satellite of mass m moving around the earth with velocity v_0 in an orbit of radius r . Because of gravitational pull of the earth, the satellite has potential energy which is given by

$$U = -\frac{GMm}{r}$$

The kinetic energy of a satellite due to its orbital motion is

$$K = \frac{1}{2}mv_0^2 = \frac{1}{2}m\left(\frac{GM}{r}\right) \left[\because v_0 = \sqrt{\frac{GM}{r}}\right]$$

Total energy of the satellite is

$$E = U + K = -\frac{GMm}{r} + \frac{1}{2}\frac{GMm}{r}$$

or
$$E = -\frac{GMm}{2r}$$

The total energy of the satellite is negative. It indicates that the satellite is bound to the earth. At infinity ($r = \infty$), the potential energy is zero and also the kinetic

energy is zero. Hence total energy at infinity is zero. Thus a negative total energy means that in order to send the satellite to infinity, it needs to be given extra energy (to make total energy zero); otherwise it will continue revolving in a closed orbit. This fact is expressed by saying that the satellite is bound to the earth.

49. What do you mean by binding energy of a satellite? Write an expression for it.

Binding energy of a satellite. The energy required by a satellite to leave its orbit around the earth and escape to infinity is called its binding energy.

The total energy of a satellite is $-\frac{GMm}{2r}$. In order to escape to infinity, it must be supplied an extra energy equal to $+\frac{GMm}{2r}$ so that its total energy E becomes equal to zero. Hence

$$\text{Binding energy of a satellite} = \frac{GMm}{2r}$$

For Your Knowledge

- ▲ The total mechanical energy of an object (say satellite in orbit), is negative if it is bound, e.g., its orbit is an ellipse or circle. But it is *not always negative*. It can be positive in which case its trajectory is a hyperbola and the object is not bound to the central star or its equivalent. These statements are evidently true when the zero of potential energy is chosen at infinity.

Examples based on Total Energy and Binding Energy of Satellite

FORMULAE USED

- Potential energy, $U = -\frac{GMm}{r}$
- Kinetic energy, $K = \frac{1}{2}mv_0^2 = \frac{1}{2}m\left(\frac{GM}{r}\right) = \frac{1}{2}\frac{GMm}{r}$
- Total energy, $E = K + U = \frac{1}{2}mv_0^2 - \frac{GMm}{r} = -\frac{GMm}{2r}$
- As $E = \frac{U}{2} = -K \therefore \Delta K = -\Delta E$ and $\Delta U = 2\Delta E$
- Binding energy = $\frac{GMm}{2r}$

UNITS USED

Masses M and m are in kg, distance r in metre, energies K , U and E in joule.

EXAMPLE 52. A 400 kg satellite is in a circular orbit of radius $2R_E$ about the earth. How much energy is required to transfer it to a circular orbit of radius $4R_E$? What are the changes in the kinetic and potential energies? [NCERT]

Solution. Total energy in orbit of radius $2R_E$,

$$E_i = -\frac{GM_E m}{4R_E} \quad \left[\because E = \frac{GMm}{2r} \right]$$

Total energy in orbit of radius $4R_E$,

$$E_f = -\frac{GM_E m}{8R_E}$$

Energy required to transfer the satellite to orbit of radius $4R_E$,

$$\begin{aligned} \Delta E &= E_f - E_i = -\frac{GM_E m}{8R_E} + \frac{GM_E m}{4R_E} \\ &= \frac{GM_E m}{8R_E} = \left(\frac{GM_E}{R_E^2} \right) \frac{mR_E}{8} = \frac{gmR_E}{8} \end{aligned}$$

But $g = 9.8 \text{ ms}^{-2}$, $m = 400 \text{ kg}$, $R_E = 6.37 \times 10^6 \text{ m}$

$$\therefore \Delta E = \frac{9.8 \times 400 \times 6.37 \times 10^6}{8} = 3.13 \times 10^9 \text{ J.}$$

Change in K.E., $\Delta K = -\Delta E = -3.13 \times 10^9 \text{ J}$

Change in P.E., $\Delta U = 2\Delta E = 6.26 \times 10^9 \text{ J.}$

EXAMPLE 53. A satellite orbits the earth at a height of 500 km from its surface. Compute its (i) kinetic energy, (ii) potential energy, and (iii) total energy. Mass of the satellite = 300 kg, Mass of the earth = $6.0 \times 10^{24} \text{ kg}$, radius of the earth = $6.4 \times 10^6 \text{ m}$, $G = 6.67 \times 10^{-11} \text{ Nm}^2 \text{ kg}^{-2}$. Will your answer alter if the earth were to shrink suddenly to half its size?

Solution. Here

$$h = 500 \text{ km} = 500 \times 10^3 \text{ m,}$$

$$m = 300 \text{ kg, } M = 6.0 \times 10^{24} \text{ kg}$$

$$R = 6.4 \times 10^6 \text{ m, } G = 6.67 \times 10^{-11} \text{ Nm}^2 \text{ kg}^{-2}$$

(i) Kinetic energy

$$\begin{aligned} &= \frac{1}{2} mv^2 = \frac{1}{2} m \cdot \frac{GM}{R+h} \quad \left[\because v = \sqrt{\frac{GM}{R+h}} \right] \\ &= \frac{1}{2} \times \frac{300 \times 6.67 \times 10^{-11} \times 6.0 \times 10^{24}}{6.4 \times 10^6 + 500 \times 10^3} \\ &= 8.7 \times 10^9 \text{ J.} \end{aligned}$$

(ii) Potential energy

$$\begin{aligned} &= -\frac{GMm}{(R+h)} = -\frac{6.67 \times 10^{-11} \times 6.0 \times 10^{24} \times 300}{6.4 \times 10^6 + 500 \times 10^3} \\ &= -17.4 \times 10^9 \text{ J.} \end{aligned}$$

(iii) Total energy

$$\begin{aligned} &= \text{K.E.} + \text{P.E.} = 8.7 \times 10^9 - 17.4 \times 10^9 \\ &= -8.7 \times 10^9 \text{ J.} \end{aligned}$$

✖ PROBLEMS FOR PRACTICE

1. A rocket is launched vertically from the surface of the earth with an initial velocity of 10 kms^{-1} . How far above the surface of the earth would it go? Radius of the earth = 6400 km and $g = 9.8 \text{ ms}^{-2}$.
(Ans. $2.5 \times 10^4 \text{ km}$)
2. A satellite of mass 250 kg is orbiting the earth at a height of 500 km above the surface of earth. How much energy must be expended to rocket the satellite out of the gravitational influence of the earth? Given mass of the earth = $6.0 \times 10^{24} \text{ kg}$, radius of the earth = 6400 km and $G = 6.67 \times 10^{-11} \text{ Nm}^2 \text{ kg}^{-2}$.
(Ans. $7.25 \times 10^9 \text{ J}$)
3. A body is to be projected vertically upwards from earth's surface to reach a height of $9R$, where R is the radius of earth. What is the velocity required to do so? Given $g = 10 \text{ ms}^{-2}$ and radius of earth = $6.4 \times 10^6 \text{ m}$.
(Ans. $1.073 \times 10^4 \text{ ms}^{-1}$)
4. Show that the velocity of a body released at a distance r from the centre of the earth, when it strikes the surface of the earth is given by

$$v = \sqrt{2GM \left(\frac{1}{R} - \frac{1}{r} \right)}$$

where R and M are the radius and mass of the earth respectively. Also show that the velocity with which the meteorites strike the surface of the earth is equal to the escape velocity.

5. Calculate the energy required to move an earth satellite of mass 10^3 kg from a circular orbit of radius $2R$ to that of radius $3R$. Given mass of the earth, $M = 5.98 \times 10^{24} \text{ kg}$ and radius of the earth, $R = 6.37 \times 10^6 \text{ m}$.
(Ans. $5.02 \times 10^9 \text{ J}$)

✖ HINTS

1. Initial K.E. of the rocket = Gain in gravitational P.E.

$$\frac{1}{2} mv^2 = -\frac{GMm}{(R+h)} - \left[-\frac{GMm}{R} \right] = \frac{GMmh}{R(R+h)}$$

$$\text{or } \frac{1}{2} v^2 = \frac{gR^2 h}{R(R+h)} = \frac{gRh}{R+h}$$

$$\text{or } \frac{R+h}{h} = \frac{2gR}{v^2} \quad \text{or } \frac{R}{h} + 1 = \frac{2gR}{v^2}$$

$$\text{or } h = R \left[\frac{2gR}{v^2} - 1 \right]^{-1}$$

$$= 6.4 \times 10^6 \left[\frac{2 \times 9.8 \times 6.4 \times 10^6}{(10^4)^2} - 1 \right]^{-1}$$

$$= 6.4 \times 10^6 \times (0.2544)^{-1} = 2.5 \times 10^7 \text{ m}$$

$$= 2.5 \times 10^4 \text{ km.}$$

2. Total energy of the satellite at height h ,

$$\begin{aligned}
 E &= \text{P.E.} + \text{K.E.} \\
 &= -\frac{GMm}{R+h} + \frac{1}{2}mv^2 = -\frac{GMm}{R+h} + \frac{GMm}{2(R+h)} \\
 &= -\frac{GMm}{2(R+h)} \quad \left[\because v = \sqrt{\frac{GM}{R+h}} \right]
 \end{aligned}$$

Energy needed to rocket out the satellite

$$\begin{aligned}
 &= -E = +\frac{GMm}{2(R+h)} \\
 &= \frac{6.67 \times 10^{-11} \times 6.0 \times 10^{24} \times 2.5}{2 \times (6.4 \times 10^6 + 5 \times 10^5)} \\
 &= 7.25 \times 10^9 \text{ J.}
 \end{aligned}$$

3. By the conservation of energy,

$$-\frac{GMm}{R} + \frac{1}{2}mv^2 = -\frac{GMm}{10R} + 0$$

$$\text{or } \frac{v^2}{2} = -\frac{GM}{10R} + \frac{GM}{R} = \frac{9GM}{10R} = \frac{9gR^2}{10R} = \frac{9gR}{10}$$

$$\begin{aligned}
 \text{or } v &= \sqrt{\frac{18gR}{10}} = \sqrt{\frac{18 \times 10 \times 6.4 \times 10^6}{10}} \\
 &= 1.073 \times 10^4 \text{ ms}^{-1}.
 \end{aligned}$$

4. As the body is initially at rest, its total initial energy

$$E_i = \text{K.E.} + \text{P.E.} = 0 - \frac{GMm}{r}$$

If v is the velocity of the body on reaching the earth's surface, then its total final energy

$$E_f = \text{K.E.} + \text{P.E.} = \frac{1}{2}mv^2 - \frac{GMm}{R}$$

By conservation of energy,

$$-\frac{GMm}{r} = \frac{1}{2}mv^2 - \frac{GMm}{R}$$

$$\text{or } v = \sqrt{2GM \left(\frac{1}{R} - \frac{1}{r} \right)}$$

As meteorites come from a large distance, $r = \infty$.

$$\therefore v = \sqrt{\frac{2GM}{R}} = 11.2 \text{ kms}^{-1}.$$

5. Total energy of a satellite,

$$\begin{aligned}
 E &= \text{P.E.} + \text{K.E.} = -\frac{GMm}{r} + \frac{1}{2}mv^2 \\
 &= -\frac{GMm}{r} + \frac{1}{2}m \cdot \frac{GM}{r} = -\frac{GMm}{2r}
 \end{aligned}$$

$$\begin{aligned}
 W &= E_f - E_i = -\frac{GMm}{2 \times 3R} + \frac{GMm}{2 \times 2R} = \frac{GMm}{12R} \\
 &= \frac{6.67 \times 10^{-11} \times 5.98 \times 10^{24} \times 10^3}{12 \times 6.37 \times 10^6} \\
 &= 5.02 \times 10^9 \text{ J.}
 \end{aligned}$$

8.28 ▼ THEORIES ABOUT PLANETARY MOTION

50. Discuss the various theories about the planetary motion.

Different theories about planetary motion. Since ancient times, scientists have been studying the motion of celestial objects like sun, planets, moon, etc. Some of these noteworthy theories are as follows :

(i) **Geocentric model.** Around 100 A.D., Greek astronomer *Ptolmey* wrote a book, *The Almagest*, in which he proposed the **geocentric model** of the planetary motion. According to this model, *the earth remained stationary at the centre and all planets, moon, sun and other stars revolved around it.* The planets revolved in small circles called *epicycles* and the centres of these epicycles moved in larger circles called *deferents*, around the earth.

(ii) **Aryabhata's contribution.** In 498 AD, the great Indian mathematician and astronomer. *Aryabhata*, proposed that *the earth revolves around the sun along with other planets and also rotates about its own axis.* He was able to explain phenomena like solar eclipse, lunar eclipse, formation of days and nights, etc. However, his ideas could not be communicated to the western world.

(iii) **Heliocentric model.** In 1543, the Polish astronomer *Nicolaus Copernicus* suggested that *the sun is at the centre of the solar system and the earth and other planets revolve around it.* This theory was called **heliocentric theory.**

(iv) **Contributions of Brahe and Kepler.** To test the validity of Copernicus model, the great Danish astronomer *Tycho Brahe* (1546–1601) made extraordinary observations by studying the motions of planets and stars without the aid of a telescope. His data were critically analysed over a period of twenty years by *Johannes Kepler* (1571–1630), who was Brahe's assistant. From these complicated data, Kepler deduced simple relations that governed planetary motion. These are three famous laws of Kepler which strongly supported the Copernicus model of solar system and played major role in the discovery of Newton's law of gravitation.

8.29 ▼ KEPLER'S LAWS OF PLANETARY MOTION

51. State and explain the Kepler's laws of planetary motion.

Kepler's laws of planetary motion. To explain the motion of the planets, Kepler formulated the following three laws :

1. Law of orbits (first law). *Each planet revolves around the sun in an elliptical orbit with the sun situated at one of the two foci.*

As shown in Fig. 8.35, the planets move around the sun in an elliptical orbit. An ellipse has two foci S and S' the sun remains at one focus S .

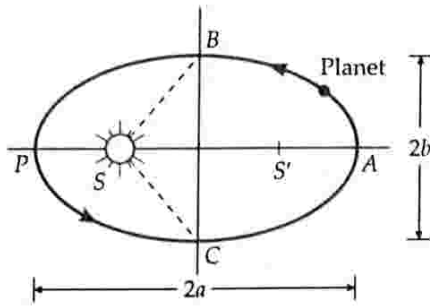

Fig. 8.35 Elliptical orbit of a planet, $PA = 2a =$ major axis, $BC = 2b =$ minor axis.

The points P and A on the orbit are called the **perihelion** and the **aphelion** and represent the closest and farthest distances from the sun respectively. The orbits of Pluto and Mercury are highly elliptical. The orbits of Neptune and Venus are circular. The orbits of other planets have slight ellipticity and may be taken as nearly circular.

2. Law of areas (second law). The radius vector drawn from the sun to a planet sweeps out equal areas in equal intervals of time i.e., the areal velocity (area covered per unit time) of a planet around the sun is constant.

Suppose a planet takes same time to go from position A to B as in going from C to D [Fig. 8.36]. From Kepler's second law, the areas ASB and CSD (covered in equal time) must be equal. Clearly, the planet covers a larger distance CD when it is near the sun than AB when it is farther away in the same interval of time. Hence the linear velocity of a planet is more when it is closer to the sun than its linear velocity when away from the sun.

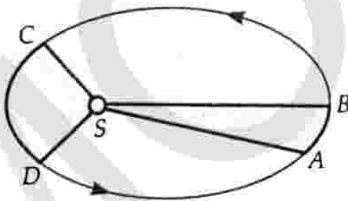

Fig. 8.36 Kepler's second law of areas.

3. Law of periods (Third law). The square of the period of revolution of a planet around the sun is proportional to the cube of the semimajor axis of its elliptical orbit.

If T is the period of revolution of a planet and R is the length of semimajor axis of its elliptical orbit, then

$$T^2 \propto R^3$$

or

$$T^2 = KR^3$$

where K is a proportionality constant.

For two different planets, we can write

$$\frac{T_1^2}{T_2^2} = \frac{R_1^3}{R_2^3}$$

Thus larger the distance of a planet from the sun, the larger will be its period of revolution around the sun. The period of revolution of the farthest planet Pluto around the sun is 247 years while that of the nearest planet mercury is 81 days.

8.30 DERIVATION OF KEPLER'S LAWS

52. What is Kepler problem ?

Kepler problem. The derivation of the Kepler's three laws of planetary motion from Newton's law of gravitation is called the Kepler problem.

53. Prove the Kepler's first law of planetary motion.

Proof of Kepler's first law of planetary motion. The planetary motion takes place under the action of the gravitational force exerted by the sun,

$$\vec{F} = -\frac{GM_s m_p}{r^3} \vec{r}$$

where M_s is the mass of the sun. This force is radial and central. Negative sign indicates that \vec{F} is oppositely directed to \vec{r} .

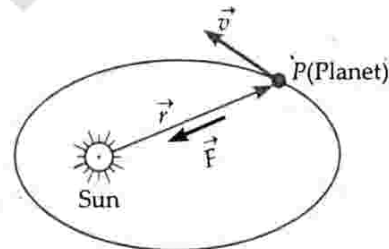

Fig. 8.37 Gravitational force on a planet due to the sun.

The torque exerted on the planet P about the sun is

$$\vec{\tau} = \vec{r} \times \vec{F} = \vec{r} \times \left(-\frac{GM_s m_p}{r^3} \right) \vec{r} = \vec{0}$$

$$[\because \vec{r} \times \vec{r} = \vec{0}]$$

But $\vec{\tau} =$ Rate of change of a regular momentum

$$= \frac{d\vec{L}}{dt}$$

$$\therefore \frac{d\vec{L}}{dt} = 0 \quad \text{or} \quad \vec{L} = \text{constant.}$$

This shows that the angular momentum of the planet about the sun remains constant both in magnitude and direction. Since the direction of $\vec{L} (= \vec{r} \times \vec{p})$ is

fixed, \vec{r} and \vec{v} lie in a plane normal to \vec{L} . Moreover, it can be shown that the central force under the action of which the planet moves varies as the square of the distance between the planet and sun and this orbit is an ellipse.

54. Prove the Kepler's second law of planetary motion.

Proof of Kepler's second law. As shown in Fig. 8.38, consider a planet moving in an elliptical orbit with the sun at focus S. Let \vec{r} be the position vector of the planet w.r.t. the sun and \vec{F} be the gravitational force on the planet due to the sun. Torque exerted on the planet by this force about the sun is

$$\vec{\tau} = \vec{r} \times \vec{F} = 0$$

[$\because \vec{r}$ and \vec{F} are oppositely directed]

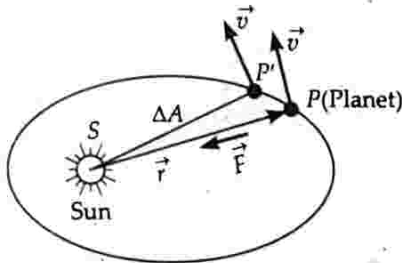

Fig. 8.38 Area swept by the radius vector in time Δt .

But
$$\vec{\tau} = \frac{d\vec{L}}{dt}$$

$$\therefore \frac{d\vec{L}}{dt} = 0 \quad \text{or} \quad \vec{L} = \text{constant}$$

Suppose the planet moves from position P to P' in time Δt . The area swept by the radius vector \vec{r} is

$$\begin{aligned} \Delta \vec{A} &= \text{Area of triangular region } SPP' \\ &= \frac{1}{2} \vec{r} \times \vec{PP}' \end{aligned}$$

But
$$\vec{PP}' = \Delta \vec{r} = \vec{v} \Delta t = \frac{\vec{p}}{m} \Delta t$$

$$\therefore \Delta \vec{A} = \frac{1}{2} \vec{r} \times \frac{\vec{p}}{m} \Delta t$$

or
$$\frac{\Delta \vec{A}}{\Delta t} = \frac{1}{2m} (\vec{r} \times \vec{p}) = \frac{\vec{L}}{2m}$$

or
$$\frac{\Delta \vec{A}}{\Delta t} = \text{constant} \quad [\because \vec{L} \text{ and } m \text{ are constant}]$$

Thus the areal velocity of the planet remains constant i.e., the radius vector joining planet to the sun sweeps out equal areas in equal intervals of time. This proves Kepler's second law of planetary motion.

55. Using Newton's law of gravitation, prove Kepler's third law of planetary motion for circular orbits.

Proof of Kepler's third law. Suppose a planet of mass m moves around the sun in a circular orbit of radius r with orbital speed v . Let M be the mass of the sun. The force of gravitation between the sun and the planet provides the necessary centripetal force.

$$\therefore \frac{mv^2}{r} = \frac{GMm}{r^2} \quad \text{or} \quad v^2 = \frac{GM}{r}$$

But orbital speed,

$$v = \frac{\text{Circumference}}{\text{Period of revolution}} = \frac{2\pi r}{T}$$

$$\therefore \frac{4\pi^2 r^2}{T^2} = \frac{GM}{r}$$

or
$$T^2 = \frac{4\pi^2}{GM} r^3 = K_s r^3$$

Thus $T^2 \propto r^3$

This proves Kepler's third law. The constant K_s is same for all planets. Its value is $2.97 \times 10^{-19} \text{ s}^2 \text{m}^{-3}$. For an elliptical orbit, r gets replaced by semi-major axis a .

8.31 ▽ DEDUCTION OF LAW OF GRAVITATION FROM KEPLER'S THIRD LAW

56. Using Kepler's law of periods, derive Newton's law of gravitation.

Proof of Newton's law of gravitation. Suppose a planet of mass m moves around the sun in a circular orbit of radius r . Let M be the mass of the sun. If v is the orbital velocity of the planet, then the required centripetal force is

$$F = \frac{mv^2}{r}$$

But orbital velocity,

$$v = \frac{\text{Circumference}}{\text{Period of revolution}} = \frac{2\pi r}{T}$$

$$\therefore F = \frac{m}{r} \times \left(\frac{2\pi r}{T}\right)^2 = \frac{4\pi^2 mr}{T^2}$$

According to Kepler's law of periods,

$$T^2 \propto r^3$$

or
$$T^2 = k r^3$$

where k is a constant. Therefore,

$$F = \frac{4\pi^2 mr}{k r^3} = \frac{4\pi^2}{k} \cdot \frac{m}{r^2}$$

As the force between the sun and the planet is mutual, it should also be proportional to the mass M of the sun.

Hence the factor,

$$\frac{4\pi^2}{k} \propto M \quad \text{or} \quad \frac{4\pi^2}{k} = GM$$

where G is another constant. So we have

$$F = G \frac{Mm}{r^2}$$

This is Newton's law of gravitation and it is applicable to any two bodies in the universe.

On the basis of Kepler's laws, Newton made the following conclusions :

1. A planet is acted upon by a centripetal force directed towards the sun.
2. The force acting on the planet is inversely proportional to the square of the distance between the planet and the sun.
3. The force acting on the planet is directly proportional to the product of the masses of the planet and the sun.

Examples based on

Kepler's Law of Planetary Motion

FORMULAE USED

1. Angular momentum, $L = mrv = \text{constant}$
2. Law of areas, $\frac{\Delta A}{\Delta t} = \text{constant}$
3. Law of periods, $T^2 \propto r^3$ or $T^2 = k r^3$. For a satellite of earth, $k = \frac{4\pi^2}{GM_E} = 10^{-13} \text{ s}^2 \text{ m}^{-3}$
4. $\frac{T_2^2}{T_1^2} = \frac{r_2^3}{r_1^3}$

UNITS USED

Time periods T_1 and T_2 are in second, distances r_1 and r_2 in metre.

EXAMPLE 54. Calculate the period of revolution of Neptune around the sun, given that diameter of its orbit is 30 times the diameter of earth's orbit around the sun, both orbits being assumed to be circular.

Solution. According to Kepler's law of periods,

$$\left[\frac{T_N}{T_E} \right]^2 = \left[\frac{r_N}{r_E} \right]^3$$

But $\frac{r_N}{r_E} = 30$ and $T_E = 1$ year

$$\therefore T_N^2 = T_E^2 \left[\frac{r_N}{r_E} \right]^3 = (1)^2 \times (30)^3 = 27000$$

$$T_N = \sqrt{27000} = 164.3 \text{ years.}$$

EXAMPLE 55. In Kepler's law of periods : $T^2 = kr^3$, the constant $k = 10^{-13} \text{ s}^2 \text{ m}^{-3}$. Express the constant k in days and kilometres. The moon is at a distance of $3.84 \times 10^5 \text{ km}$ from earth. Obtain its time-period of revolution in days.

[NCERT]

Solution. Given $k = 10^{-13} \frac{\text{s}^2}{\text{m}^3}$

$$\text{As } 1 \text{ s} = \frac{1}{24 \times 60 \times 60} \text{ day and } 1 \text{ m} = \frac{1}{1000} \text{ km}$$

$$\therefore k = 10^{-13} \times \frac{1}{(24 \times 60 \times 60)^2} \text{ d}^2 \frac{1}{(1/1000)^3} \text{ km}^{-3}$$

$$= 1.33 \times 10^{-14} \text{ d}^2 \text{ km}^{-3}.$$

For the moon, $r = 3.84 \times 10^5 \text{ km}$.

$$\therefore T^2 = kr^3 = 1.33 \times 10^{-14} \times (3.84 \times 10^5)^3$$

$$= 27.3 \text{ days.}$$

EXAMPLE 56. In an imaginary planetary system, the central star has the same mass as our sun, but is brighter so that only a planet twice the distance between the earth and the sun can support life. Assuming biological evolution (including aging process etc.) on that planet similar to ours, what would be the average life span of a 'human' on that planet in terms of its natural year? The average life span of a human on the earth may be taken to be 70 years.

Solution. According to Kepler's law of periods,

$$\left(\frac{T_1}{T_2} \right)^2 = \left(\frac{R_1}{R_2} \right)^3$$

Here,

T_1 = Average life span of a human on the earth
= 70 years.

T_2 = Average life span of a human on the planet
= ?

R_1 = Distance between the earth and the planet
= $2 R_2$

R_2 = Distance between the earth and the sun.

$$\therefore \left(\frac{70}{T_2} \right)^2 = \left(\frac{2 R_2}{R_2} \right)^3$$

$$\text{or } \frac{70 \times 70}{T_2^2} = 8$$

$$\text{or } T_2^2 = \frac{70 \times 70}{8}$$

$$\therefore T_2 = \frac{70}{\sqrt{8}} = 25 \text{ planet years.}$$

EXAMPLE 57. The planet Mars has two moons, Phobos and Deimos. (i) Phobos has a period 7 hours, 39 minutes and an orbital radius of $9.4 \times 10^3 \text{ km}$. Calculate the mass of Mars.

(ii) Assume that Earth and Mars move in circular orbits around the Sun, with the Martian orbit being 1.52 times the orbital radius of the Earth. What is the length of the Martian year in days? [NCERT ; Delhi 08]

Solution. (i) Here $r = 9.4 \times 10^6$ m

$$T = 7 \text{ h } 39 \text{ min} = 459 \text{ min} = 459 \times 60 \text{ s}$$

Mass of Mars,

$$M_M = \frac{4\pi^2 r^3}{GT^2} = \frac{4 \times 9.87 \times (9.4)^3 \times 10^{18}}{6.67 \times 10^{-11} \times (459 \times 60)^2}$$

$$= 6.48 \times 10^{23} \text{ kg.}$$

(ii) Here $r_M = 1.52 r_E$, $T_E = 365$ days

According to Kepler's law of periods,

$$\frac{T_M^2}{T_E^2} = \frac{R_M^3}{R_E^3}$$

$$\therefore T_M = \left(\frac{R_M}{R_E} \right)^{3/2} T_E$$

$$= (1.52)^{3/2} \times 365 = 684 \text{ days.}$$

EXAMPLE 58. The distances of two planets from the sun are 10^{13} m and 10^{12} m respectively. Find the ratio of time periods and speeds of the two planets.

Solution. Here $r_1 = 10^{13}$ m, $r_2 = 10^{12}$ m

From Kepler's third law,

$$\frac{T_1}{T_2} = \left[\frac{r_1}{r_2} \right]^{3/2} = \left[\frac{10^{13}}{10^{12}} \right]^{3/2} = 10 \sqrt{10}.$$

If v_1 and v_2 are the orbital speeds of the planets, then

$$v_1 = \frac{2\pi r_1}{T_1} \quad \text{and} \quad v_2 = \frac{2\pi r_2}{T_2}$$

$$\therefore \frac{v_1}{v_2} = \frac{r_1}{r_2} \cdot \frac{T_2}{T_1} = \frac{r_1}{r_2} \left[\frac{r_2}{r_1} \right]^{3/2} = \left[\frac{r_2}{r_1} \right]^{1/2}$$

$$= \left[\frac{10^{12}}{10^{13}} \right]^{1/2} = 1/\sqrt{10}.$$

EXAMPLE 59. Let the speed of the planet at the perihelion P in Fig. 8.35 be v_p and the sun-planet distance SP be r_p . Relate $\{r_p, v_p\}$ to the corresponding quantities at the aphelion $\{r_A, v_A\}$. Will the planet take equal times to traverse BAC and CPB ? [NCERT]

Solution. At any point, the radius vector and velocity vector of the planet are mutually perpendicular. Angular momentum of the planet at the perihelion P is

$$L_p = m_p r_p v_p$$

Similarly, at the aphelion,

$$L_A = m_p r_A v_A$$

By conservation of angular momentum,

$$L_p = L_A$$

$$\text{or} \quad m_p r_p v_p = m_p r_A v_A$$

$$\text{or} \quad \frac{v_p}{v_A} = \frac{r_A}{r_p}$$

As $r_A > r_p$, so $v_p > v_A$.

To traverse BAC , area swept by radius vector = Area $SBAC$.

To traverse CPB , area swept by radius vector = Area $SBPC$.

But Area $SBAC >$ Area $SBPC$.

From Kepler's second law, equal areas are swept in equal times. Hence the planet will take a longer time to traverse BAC than CPB .

✱ PROBLEMS FOR PRACTICE

- The distance of Venus from the sun is 0.72 AU. Find the orbital period of Venus. [CBSE 93C ; Delhi 06]
(Ans. 223 days)
- If the earth be one half its present distance from the sun, how many days will the present one year on the surface of earth change?
(Ans. Year decreases by 236 days)
- The distance of planet Jupiter from the sun is 5.2 times that of the earth. Find the period of revolution of Jupiter around the sun. (Ans. 11.86 years)
- The planet Neptune travels around the sun with a period of 165 years. Show that the radius of its orbit is approximately 30 times that of earth's orbit, both being considered as circular.
- A geostationary satellite is orbiting the earth at a height $6R$ above the surface of earth, where R is the radius of the earth. Find the time period of another satellite at a height of $2.5R$ from the surface of earth in hours. [IIT 87]
(Ans. $6\sqrt{2}$ h)
- The radius of earth's orbit is 1.5×10^8 km and that of Mars is 2.5×10^{11} m. In how many years, does the Mars complete its one revolution? (Ans. 2.15 years)
- A planet of mass m moves around the sun of mass M in an elliptical orbit. The maximum and minimum distances of the planet from the sun are r_1 and r_2 respectively. Find the relation for the time period of the planet in terms of r_1 and r_2 .
(Ans. $T \propto (r_1 + r_2)^{3/2}$)

✱ HINTS

- For the earth, $T_1 = 1$ year, $r_1 = 1$ AU
For the planet Venus, $T_2 = ?$ $r_2 = 0.72$ AU

$$\therefore T_2^2 = T_1^2 \cdot \left[\frac{r_2}{r_1} \right]^3 = 1^2 \times \left[\frac{0.72}{1} \right]^3 = 0.37 \text{ yr}^2$$

$$\text{or } T_2 = \sqrt{0.37} = 0.61 \text{ yr} = 223 \text{ days.}$$

$$2. \text{ Here } T_1 = 365 \text{ days, } R_1 = r, R_2 = r/2$$

$$T_2 = T_1 \left(\frac{r_2}{r_1} \right)^{3/2} = 365 \left(\frac{r/2}{r} \right)^{3/2} = 129 \text{ days}$$

$$\text{Decrease in the number of days in one year} \\ = 365 - 129 = 236 \text{ days.}$$

$$3. T_J = T_E \left[\frac{r_J}{r_E} \right]^{3/2} = 1 \times \left[\frac{5.2 r_E}{r_E} \right]^{3/2} = 11.86 \text{ years.}$$

$$4. \text{ Here } T_1 = 1 \text{ year, } T_2 = 165 \text{ years}$$

$$\therefore R_2 = R_1 \left[\frac{T_2}{T_1} \right]^{2/3} = R_1 \times \left[\frac{165}{1} \right]^{2/3} \approx 30 R_1.$$

$$5. \text{ Here } r_1 = 6R + R = 7R, T_1 = 24 \text{ h}$$

$$r_2 = 2.5R + R = 3.5R, T_2 = ?$$

$$T_2 = T_1 \left[\frac{r_2}{r_1} \right]^{3/2} = 24 \left[\frac{3.5R}{7R} \right]^{3/2} = \frac{24}{2\sqrt{2}} = 6\sqrt{2} \text{ h.}$$

$$6. \text{ Here } r_1 = 1.5 \times 10^8 \text{ km} = 1.5 \times 10^{11} \text{ m,}$$

$$r_2 = 2.5 \times 10^{11} \text{ m, } T_1 = 1 \text{ year}$$

$$T_2 = \left[\frac{R_2}{R_1} \right]^{3/2} \times T_1 = \left[\frac{2.5 \times 10^{11}}{1.5 \times 10^{11}} \right]^{3/2} \times 1 = \left[\frac{5}{3} \right]^{3/2}$$

$$= 2.15 \text{ years.}$$

7. Semimajor axis of the elliptical orbit of the plane around the sun, $r = (r_1 + r_2)/2$. According to Kepler's third law,

$$T^2 \propto \left(\frac{r_1 + r_2}{2} \right)^3 \quad \text{or} \quad T \propto \left(\frac{r_1 + r_2}{2} \right)^{3/2}$$

$$\text{or } T \propto (r_1 + r_2)^{3/2}.$$

8.32 WEIGHTLESSNESS

57. What is weightlessness? How does weightlessness arise in various situations? Give some problems of weightlessness.

Weightlessness. When a body presses against a supporting surface, the supporting surface exerts a force of reaction on him. This force of reaction produces the feeling of weight in the body. If somehow the force of reaction becomes zero, the apparent weight of the body becomes zero.

A body is said to be in a state of weightlessness when the reaction of the supporting surface is zero or its apparent weight is zero.

A body can be in the state of weightlessness under the following circumstances:

(i) **In a freely falling lift.** Consider a person of true weight mg standing in a lift which is moving vertically downwards with acceleration a . If R is the reaction of the floor on the man, then

$$mg - R = ma$$

\therefore Apparent weight,

$$R = m(g - a)$$

If the cable of the lift breaks, it begins to fall freely. Then $a = g$, and

$$R = m(g - g) = 0$$

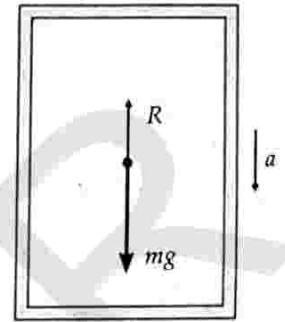

Fig. 8.39 Lift moving downwards.

Thus the apparent weight of the man becomes zero. Both the man and the lift are moving downwards with the same acceleration g . There are no forces of action and reaction between them. Hence the man falling freely develops a feeling of weightlessness.

(ii) **Inside a spacecraft.** Consider a spacecraft revolving around the earth in an orbit of radius r . The acceleration of the satellite is GM/r^2 , towards the centre of the earth. Here M is the mass of the earth. Suppose a body of mass m lies on an inside surface of the satellite. Forces acting on this body will be

$$(a) \text{ Gravitational pull of the earth} = \frac{GMm}{r^2}.$$

(b) Reaction force R of the surface.

By Newton's second law,

$$\frac{GMm}{r^2} - R = ma = m \left(\frac{GM}{r^2} \right)$$

$$\therefore R = 0$$

Thus the surface does not exert any force on the body and hence its apparent weight is zero. That is why, an astronaut sees all the bodies floating weightlessly inside the spacecraft.

(iii) **At null points in space.** At certain points in space, called the null points, the gravitational forces due to various masses cancel out. As the value of g is zero at these points, so the effective weight of the body is zero.

(iv) **At the centre of the earth.** As the value of g is zero at the centre of the earth, so weight of a body is zero at the centre of the earth.

Problems of weightlessness:

(i) Eating and drinking become difficult in the state of weightlessness. An astronaut cannot

drink water from a glass because on tilting the glass, the water comes out in the form of floating drops. He takes food in the form of paste from tube squeezed into his mouth.

- (ii) Space-flight for a long time adversely affects the human organism.
- (iii) While walking in a space craft, an astronaut is pushed away from the floor and he may crash against the ceiling of the spacecraft.
- (iv) It is not possible to perform experiments on simple pendulum in the state of weightlessness. As $g = 0$, so $T = 2\pi\sqrt{L/g} = \infty$.

For Your Knowledge

- ▲ When a body is in a free fall, a gravitational pull mg does act on it. It is said to be weightless because it exerts no force on its support.
- ▲ An astronaut experiences weightlessness in space. This is not because the gravitational force is small on him. It is because the astronaut and the satellite both are in a state of free fall towards the earth.
- ▲ In the state of weightlessness, though the bodies have no weight, they have inertia on account of their mass. So bodies floating in a space craft may collide with each other and crash.

8.33 INERTIAL AND GRAVITATIONAL MASS

58. What is inertial mass of a body? Give its important properties.

Inertial mass. The mass of a body which measures its inertia is called its inertial mass. It is equal to the ratio of the external force applied on the body to the acceleration produced in it along a smooth horizontal surface.

$$\text{Inertial mass} = \frac{\text{Applied force}}{\text{Acceleration produced}}$$

or
$$m_i = \frac{F}{a}$$

The inertial mass of a body is a measure of its ability to resist the production of acceleration by an external force. If some force is applied on two different bodies, then the inertial mass of that body will be more in which the acceleration produced is less and vice versa.

Properties of inertial mass :

1. Inertial mass of a body is directly proportional to the quantity of matter possessed by it.
2. It is independent of size, shape and state of the body.
3. It is conserved both in physical and chemical processes.
4. It is not affected by the presence of other bodies.

5. When different bodies are put together, their inertial masses get added together irrespective of the nature of their materials.
6. The inertial mass of a body increases with its speed. When a body of rest mass m_0 moves with speed v , its inertial mass will be

$$m = \frac{m_0}{\sqrt{1 - \frac{v^2}{c^2}}}$$

59. What is gravitational mass of a body? Explain its equivalence with inertial mass.

Gravitational mass. The mass of a body which determines the gravitational pull due to earth acting upon it is called its gravitational mass. If M is the mass of the earth and R its radius, then according to Newton's law of gravitation, the gravitational pull acting on a body of mass m_g placed on the earth's surface is given by

$$F = \frac{GMm_g}{R^2}$$

$$\therefore \text{Gravitational mass, } m_g = \frac{FR^2}{GM}$$

Greater the gravitational mass of a body, greater is the gravitational pull of the earth on it. So if two bodies lying at equal heights from the ground experience equal force of gravity, then their gravitational masses must be equal. This forms the principle of a pan balance.

Equivalence of inertial and gravitational masses. According to Newton's law of gravitation, the gravitational force acting on a body of gravitational mass m_g placed on the surface of the earth is given by

$$F = \frac{GMm_g}{R^2}$$

If a body of inertial mass m_i is allowed to fall freely, then from Newton's second law,

$$F = \text{Inertial mass} \times \text{acceleration due to gravity} = m_i g$$

From the above two equations, we get

$$m_i g = \frac{GMm_g}{R^2}$$

or
$$\frac{m_i}{m_g} = \frac{GM}{gR^2} = k \text{ (a constant)}$$

or
$$m_i = km_g \quad \text{or} \quad m_i \propto m_g$$

Thus the inertial mass of a body is proportional to its gravitational mass. In fact the proportionality constant, $k = 1$, so that $m_i = m_g$ i.e., inertial and gravitational masses are equivalent. Hence in the force equation $F = ma$ and weight equation $W = mg$, we need to consider only one type of mass m .

60. Give a comparison of inertial and gravitational masses.

Comparison between inertial and gravitational masses :

Similarities :

1. Both represent the quantity of matter in a body.
2. Both are equivalent in magnitude and have same units of measurement.
3. Both do not depend on the shape or state of matter.
4. Both are not affected by the presence of other bodies.
5. Both are scalar quantities.

Differences :

1. Inertial mass is the measure of difficulty of accelerating a body while gravitational mass measures the force of attraction between the body and the earth.
2. Inertial mass is determined from Newton's second law of motion while gravitational mass is determined from Newton's law of gravitation.
3. Inertial mass can be measured only under dynamic conditions *i.e.*, when the body is in motion, which is neither convenient nor practical. Gravitational mass can be easily measured by using a common balance.

61. Give an illustration to distinguish between inertial and gravitational masses.

How did Einstein experimentally prove the equivalence of inertial and gravitational masses. How did it help in forming the general theory of relativity ?

Einstein's view of gravitation. Einstein pointed out that *gravitation and acceleration are equivalent*. This is called **principle of equivalence**. Einstein used this principle as one of the basic ideas in forming his *general theory of relativity* that explains gravitational effects in terms of curvature of space. He proved the equivalence of inertial and gravitation masses by the following simple experiment.

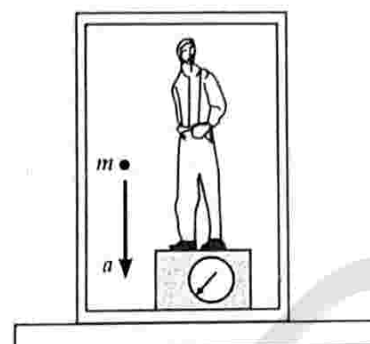

(a) The Einstein box at rest on earth's surface.

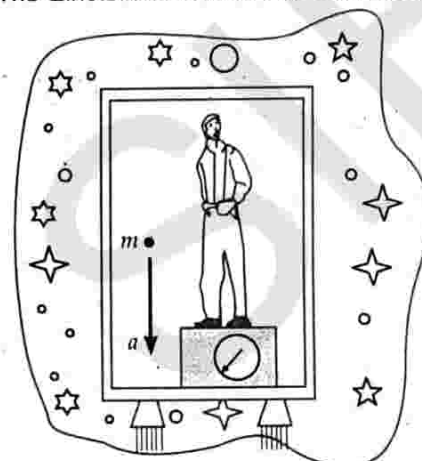

(b) The Einstein box accelerating through interstellar space at 9.8 ms^{-2} .

Fig. 8.40

Consider a person enclosed in small box, called **Einstein box**. In Fig. 8.40(a), the box is at rest on earth's surface and is subject only to earth's gravitational force. In Fig. 8.40(b), the box is accelerating through interstellar space at 9.8 ms^{-2} and is subject only to the external force producing this much acceleration. It is not possible, by doing experiments within the box, for the person to tell which situation he is in [*i.e.*, (a) or (b)]. For example, the platform scale on which he stands reads the same weight in both cases. Moreover, if he observes an object falling past him, the object has the same acceleration relative to him in both cases. This conclusively proves the equivalence of inertial and gravitational masses.

Very Short Answer Conceptual Problems

Problem 1. Why is the law of gravitation called the universal law ?

Solution. This is because of the fact that the law of gravitation holds good for any pair of bodies in the universe whether microscopically small or astronomically large in size.

Problem 2. Why is G called the universal gravitational constant ?

Solution. This is because the value of G is same for any pair of the bodies in the universe. It does not depend on the nature of the medium between the two bodies or on the nature of the bodies themselves.

Problem 3. What is the ratio of the force of attraction between two bodies kept in air and the same distance apart in water ?

Solution. 1:1, because the gravitational force does not depend on the nature of the medium.

Problem 4. If spheres of same material and same radius r are touching each other, then show that the gravitational force between them is directly proportional to r^4 .

Solution. If ρ is the density of the material, then

$$F = G \frac{m_1 m_2}{(2r)^2} = G \frac{\frac{4}{3} \pi r^3 \rho \times \frac{4}{3} \pi r^3 \rho}{(2r)^2} = \frac{4}{9} \pi^2 \rho^2 G r^4$$

Clearly, $F \propto r^4$.

Problem 5. If the density of planet is doubled without any change in its radius, how does g change on the planet ?

Solution. It gets doubled, because $g \propto \rho$.

Problem 6. Is it possible to shield a body from gravitational effects ?

Solution. No, it is not possible to shield a body from gravitational effects because gravitational interaction does not depend upon the nature of the intervening medium.

Problem 7. If the force of gravity acts on all bodies in proportion to their masses, why does a heavy body not fall faster than a light body ? [Delhi 12]

Solution. If F be the gravitational force on a body of mass m , then

$$F = G \frac{Mm}{R^2} = mg \quad \text{or} \quad g = \frac{GM}{R^2}$$

Clearly, $F \propto m$ but g does not depend on m . Hence all bodies fall with same rapidness if there is no air resistance.

Problem 8. The mass of the moon is nearly 10% of the mass of the earth. What will be the gravitational force of the earth on the moon, in comparison to the gravitational force of the moon on the earth ?

Solution. Both forces will be equal in magnitude as gravitational force between two bodies is a mutual force.

Problem 9. Earth is continuously pulling the moon towards its centre, still it does not fall to the earth. Why ?

Solution. Gravitational force of attraction due to earth provides the centripetal force, which keeps the moon in orbit around the earth. Moreover, this gravitational force acts perpendicular to the velocity of the moon.

Problem 10. We cannot move finger without disturbing all stars. Why ?

Solution. When we move our finger, the distance between the objects and our finger changes. Hence, the force of attraction changes, disturbing the entire universe, including the stars.

Problem 11. According to Newton's law of gravitation, the apple and the earth experience equal and opposite forces due to gravitation. But it is the apple that falls towards the earth and not vice-versa. Why ?

[Delhi 1999]

Solution. According to Newton's third law of motion, the force with which the earth is attracted towards the apple is equal to the force with which earth attracts the apple. However, the mass of the earth is extremely large as compared to that of apple. So acceleration of the earth is very small and is not noticeable.

Problem 12. According to Newton's law of gravitation, every particle of matter attracts every other particle. But bodies on the surface of earth never move towards each other on account of this force of attraction. Why ? [NCERT]

Solution. Because of their small masses, the gravitational attraction between two bodies is too small to produce any motion in them. But due to the large mass of the earth, the gravitational attraction between the bodies and earth is very large and so all bodies are attracted towards the centre of the earth.

Problem 13. Does the gravitational force of attraction of the earth become zero at some height above the earth ? Give reason.

Solution. No, the gravitational force of attraction of earth on a body at height h is

$$F = G \frac{Mm}{(R+h)^2}$$

Clearly, F will be zero only when h is infinity.

Problem 14. Which is more fundamental-mass or weight of a body ?

Solution. Mass is more fundamental than weight because the mass of a body remains constant while its weight changes from place to place due to change in the value of g .

Problem 15. If the diameter of the earth becomes twice its present value but its mass remains unchanged, then how would be the weight of an object on the surface of the earth affected ? [Roorkee 80]

Solution. Weight of body,

$$W = mg = \frac{GMm}{R^2}$$

When the diameter or radius of the earth becomes double its present value, the weight of the body will be

$$W' = \frac{GMm}{(2R)^2} = \frac{1}{4} W$$

i.e., weight will become one-fourth of the present value.

Problem 16. If the diameter of the earth becomes half its present value but its average density remains unchanged then how would be the weight of an object on the surface of the earth affected ?

Solution. Acceleration due to gravity on the surface of the earth

$$g = \frac{GM}{R^2} = \frac{G}{R^2} \times \frac{4}{3} \pi R^3 \rho = \frac{4}{3} \pi GR \rho$$

When the diameter or radius becomes half its present value,

$$g' = \frac{4}{3} \pi G \left(\frac{R}{2} \right) \rho = \frac{g}{2}$$

Hence the weight of the object will be halved.

Problem 17. The mass and diameter of a planet are twice those of the earth. What will be the time-period of that pendulum on this planet, which is a second's pendulum on the earth? [IIT]

Solution. Initially, $g = \frac{GM}{R^2}$ and $T = 2\pi \sqrt{\frac{l}{g}} = 2$ s

(For a second's pendulum)

When M and R are doubled,

$$g' = \frac{G(2M)}{(2R)^2} = \frac{g}{2}$$

and $T' = 2\pi \sqrt{\frac{l}{g/2}} = \sqrt{2} T = 2\sqrt{2}$ s.

Problem 18. If the radii of two planets be R_1 and R_2 and their mean densities be ρ_1 and ρ_2 , then prove that the ratio of accelerations due to gravity on the planets will be $R_1 \rho_1 : R_2 \rho_2$.

Solution. On the surface of any planet, $g = \frac{4}{3} \pi GR \rho$

$$\therefore \frac{g_1}{g_2} = \frac{\frac{4}{3} \pi GR_1 \rho_1}{\frac{4}{3} \pi GR_2 \rho_2} = R_1 \rho_1 : R_2 \rho_2$$

Problem 19. The distance between two bodies A and B is r . Taking the gravitational force according to the law of inverse square of r , the acceleration of the body is a . If the gravitational force follows an inverse fourth power law, then what would be the acceleration of the body A ?

Solution. For inverse square law, $F = \frac{Gm_1 m_2}{r^2}$

$$\therefore \text{Acceleration of body } A = \frac{F}{m_1} = \frac{Gm_2}{r^2} = a$$

For inverse fourth power law, $F' = \frac{Gm_1 m_2}{r^4}$

$$\therefore \text{Acceleration of body } A = \frac{F'}{m_1} = \frac{Gm_2}{r^4} = \frac{a}{r^2}$$

Problem 20. Why is centre of mass of a body often called its centre of gravity?

Solution. The torque due to gravity on a body acts as if its entire mass were concentrated at its centre of mass. That is why centre of mass of a body is often called its centre of gravity.

Problem 21. Why the value of g is more at the poles than at the equator?

Solution. As $g = \left(\frac{GM}{R^2} \right)$ and the value of R at equator is greater than that at poles, hence g at poles is greater than g at equator.

Problem 22. Why a body weighs more at the poles than at the equator? [Himachal 03]

Solution. At the poles $g_p > g_e$, hence, $mg_p > mg_e$.

Problem 23. Where does a body weigh more? At the sea level or on the mountains?

Solution. At the sea level because weight decreases with altitude.

Problem 24. Where will a body weigh more – 1 km above the surface of earth or 1 km below the surface of earth?

Solution. As $g_h = g \left(1 - \frac{2h}{d} \right)$ and $g_d = g \left(1 - \frac{d}{h} \right)$

For $h = d = 1$ km, clearly $g_d > g_p$.

Hence the body will weigh more at a depth of 1 km below the surface of earth.

Problem 25. Does the concentration of the earth's mass near its centre change the variation of g with height compared with a homogeneous sphere? How?

Solution. Any change in the distribution of the earth's mass will not affect the variation of acceleration due to gravity with height. This is because for a point outside the earth, the whole mass of the earth is 'effective' and the earth behaves as a homogeneous sphere.

Problem 26. The weight of a body is less inside the earth than on the surface. Why?

Solution. As we go inside the earth, the value of the attracting mass M decreases and hence the value of g decreases. Therefore, the weight of the body mg is less inside the earth than on the surface.

Problem 27. Why do you feel giddy while moving on a merry-go-round?

Solution. When moving in a merry-go-round, our weight appears to decrease when we move down and appears to increase when we move up.

Problem 28. At which place on earth's surface, the value of g is largest and why?

Solution. The value of g is largest at the poles due to following two reasons:

- Distance of poles from the centre of earth is smaller than the distance of any other point on earth's surface from its centre.
- At poles, no centrifugal force acts on the body.

Problem 29. When dropped from the same height a body reaches the ground quicker at poles than at the equator. Why ?

Solution. The acceleration due to gravity is more at the poles than at the equator. When the initial velocities and distances travelled are the same, the time taken by the body is smaller if the acceleration due to gravity is large. Hence, when dropped from the same height, a body reaches the ground quicker at the poles than at the equator.

Problem 30. When a clock controlled by a pendulum is taken from the plains to a mountain, it becomes slow but a wrist-watch controlled by a spring remains unaffected. Explain the reason for the difference in the behaviour of the two watches.

Solution. Due to decrease in the value of g at the mountain, the time period of the pendulum of the clock increases. On the other hand, the spring watch remains unaffected by the variation in g .

Problem 31. A clock fitted with a pendulum and another with a spring indicate correct time on earth. Which shows correct time on the moon ?

Solution. A clock fitted with a spring will show correct time on the moon, because its time period is not affected by the variation in g .

Problem 32. Why does a tennis ball bounce higher on a hill than on plains ?

[Himachal 03]

Solution. The value of g is less on hills because they are comparatively at a greater distance from the centre of the earth. Therefore, the gravitational pull on the tennis ball is less on hill tops and so it bounces higher on hills than on plains.

Problem 33. A man can jump six times as high on the moon as that on the earth. Justify.

Or

Explain, why one can jump higher on the surface of the moon than that on the earth.

[Himachal 07]

Solution. The value of ' g ' on the surface of moon is about $\frac{1}{6}$ th of its value on the surface of earth.

For the same gain of P.E. in both cases, we have

$$mg_m h_m = mg_e h_e$$

$$\text{or } h_m = \frac{g_e h_e}{g_m} = \frac{g_e h_e}{g_e / 6} = 6h_e$$

Problem 34. Moon-travellers tie heavy weight at their back before landing on the moon. Why ?

Solution. Due to the small value of g on the moon, the traveller would weigh less. To compensate for this loss in weight, the travellers load their backs with heavy weight.

Problem 35. Why is earth flat at the poles ?

Solution. Due to its rotation about the polar axis.

Problem 36. What is the effect of rotation of the earth on the acceleration due to gravity ?

Solution. The acceleration due to gravity decreases due to rotation of the earth. This effect is zero at the poles and maximum at the equator.

Problem 37. Name two factors which determine whether a planet would have an atmosphere or not.

[Himachal 06 ; Delhi 99]

Solution. The two such factors are

- The value of acceleration due to gravity on the planet.
- Surface temperature of the planet.

Problem 38. If the earth stops rotating about its axis, what will be the effect on the value of g ? Will this effect be same at all places ?

Solution. The value of g will increase at all places except at the poles. The increase will be different at different places, maximum at the equator.

Problem 38(a). If the earth stops rotating about its axis, then by what value will the acceleration due to gravity change at the equator ?

Solution. The value of g increases by $\omega^2 R$.

Problem 39. Explain why tidal waves (high tide and low tide) are formed on seas.

Solution. The gravitational attraction of moon on sea water causes high tides. Tides at one place cause low tides (ebbs) at another. Attraction by sun also causes tides but only of half the magnitude. Hence on new moon and full moon days, when both effects add, tides are very high.

Problem 40. Why are we not thrown off the surface of the earth by the centrifugal force ?

Solution. The force of gravity exerted on our body by the earth towards its centre is greater than centrifugal force acting on our body away from the centre.

Problem 41. A satellite does not need any fuel to circle around the earth. Why ?

[Himachal 05]

Solution. The gravitational force between satellite and earth provides the centripetal force required by the satellite to move in a circular orbit.

Problem 42. Why a multi-stage rocket is required to launch a satellite ?

Solution. The multistage rocket helps to economise the consumption of fuel.

Problem 43. Why do different planets have different escape velocities ?

[Himachal 06]

Solution. As $v_e = \sqrt{\frac{2GM}{R}}$, therefore escape velocities have different values on different planets which are of different masses and different sizes.

Problem 44. An elephant and an ant are to be projected out of earth into space. Do we need different velocities to do so ?

Solution. The escape velocity, $v_e = \sqrt{2gR}$, does not depend upon the mass of the projected body. Thus we need the same velocity to project an elephant and an ant into space.

Problem 45. Does a rocket really need the escape velocity of 11.2 kms^{-1} initially to escape from the earth ?

Solution. No, rocket can have any velocity at the start. The rocket can continue to increase the velocity due to thrust provided by the escaping gases that will carry it to a desired position.

Problem 46. The moon has no atmosphere. Why ?

[Himachal 03, 05 ; Delhi 05C, 10]

Solution. Due to the small value of 'g', the escape velocity on the moon surface is small (2.38 kms^{-1}). The air molecules have thermal velocities greater than the escape velocity. Therefore, the air molecules escape away and cannot form atmosphere on the moon.

Problem 47. The earth has atmosphere. Why ?

Solution. Because the r.m.s. velocity of air molecules is less than escape velocity on the earth, the air cannot escape from the surface of the earth. Hence the earth has atmosphere.

Problem 48. Lighter gases like H_2 , He, etc. are rare in the atmosphere of the earth. Why ?

Solution. Usually the average velocity of the molecules of lighter gases is greater than the escape velocity at the earth's surface. So lighter gases have escaped from the earth's atmosphere.

Problem 49. The gravitational force exerted by the sun on the moon is greater than (about twice as great as) the gravitational force exerted by the earth on the moon. Why then doesn't the moon escape from the earth (during a solar eclipse, for example) ?

Solution. The moon can escape only if the moon has no orbital motion. In fact, while revolving around the earth, the moon has orbital motion around the sun also. The gravitational attraction of the sun on the moon provides the centripetal force required for the orbital motion around the sun.

Problem 50. The escape velocity for a satellite is 11.2 kms^{-1} . If the satellite is launched at an angle of 60° with the vertical, what will be the escape velocity ?

Solution. 11.2 kms^{-1} , because escape velocity ($v_e = \sqrt{2GM/R}$) does not depend on the angle of projection.

Problem 51. An astronaut, while revolving in a circular orbit happens to throw a spoon outside. Will the spoon reach the surface of the earth ?

Solution. The spoon will continue to move in the same circular orbit, and chase the astronaut. It will never reach the surface of the earth.

Problem 52. An artificial satellite revolves around the earth without using any fuel. On the other hand, an aeroplane requires fuel to fly. Why ?

Solution. Air is essential for an aeroplane to fly. To overcome the resistive forces of air, aeroplane requires fuel. The satellite orbits at a much higher height where air resistance is negligible and so it needs no fuel.

Problem 53. Why are space rockets usually launched from west to east in the equatorial plane ?

Solution. Due to rotation of the earth about its polar axis, every particle on the earth has a linear velocity directed from west to east. This velocity ($v = R\omega$) is maximum at the equator. When a rocket is launched from west to east, this maximum velocity gets added to the launching velocity, so the launching becomes easier.

Problem 54. A satellite of small mass burns during its descent and not during ascent. Why ?

Solution. The speed of the satellite during descent is much larger than that during its ascent. As the air resistance is directly proportional to velocity, so heat produced during descent is very large and the satellite burns up.

Problem 55. Is it possible to place an artificial satellite in an orbit such that it is always visible over New Delhi ?

Solution. No. A satellite remains always visible only if it revolves in the equatorial plane with a period of revolution equal to that of the earth. New Delhi does not lie in the region of equatorial plane.

Problem 56. The astronauts in a satellite orbiting the earth feel weightlessness. Does the weightlessness depend upon the distance of the satellite from the earth ? Give reason.

Solution. No. The gravitational acceleration of the astronaut relative to the satellite is zero, whatever be the distance of the satellite from the earth.

Problem 57. Can we determine the gravitational mass of a body inside an artificial satellite ?

Solution. No, because both the body and the artificial satellite are in a state of free fall.

Problem 58. A satellite is orbiting the earth with speed v_0 . To make the satellite escape, what should be the minimum percentage increase in its velocity ?

Solution. Required percentage increase in velocity

$$\begin{aligned} &= \frac{v_e - v_0}{v_0} \times 100 = \left(\frac{v_e}{v_0} - 1 \right) \times 100 \\ &= (\sqrt{2} - 1) \times 100 = 41.4\%. \end{aligned}$$

Problem 59. Why an astronaut in an orbiting space-craft is not in zero gravity although weightless ?

[Delhi 1997]

Solution. The astronaut in the orbiting spacecraft is still in the gravitational field of the earth and experiences appreciable gravity. However, the gravity is used up in providing the necessary centripetal force.

Problem 60. Why does an astronaut in a spacecraft feel weightlessness ?

Solution. This is because the orbiting spacecraft along with the astronaut is in a state of free fall towards the earth.

Problem 61. Two identical geostationary satellites are moving with equal speeds in the same orbit but their sense of rotation brings them on a collision course. What will happen to the debris ?

Solution. The collision between the two satellites is inelastic. They stick together.

$$mv + (-mv) = (m + m)V \quad \text{or} \quad V = 0$$

The kinetic energy of the debris in its orbit will be zero. Due to gravity, it falls to the surface of the earth and in the course of its journey, it may get burnt up.

Problem 62. The linear speed of a rocket is not constant in its orbit. Comment.

Solution. The areal velocity of a planet around the sun is constant but its linear speed continuously changes. The linear speed of the planet is large when it passes close to the sun and is small when the planet is away from the sun.

Problem 63. Identify the portion of sun in the following diagram if the linear speed of the planet is greater at C compared to that at D. [Central Schools 03]

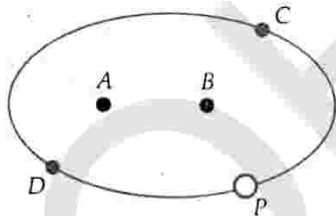

Fig. 8.41

Solution. The sun should be at position B, because the speed of a planet is greater when it is closer to the sun.

Problem 64. The largest and shortest distances of the earth from the sun are r_1 and r_2 respectively. What is the distance from the sun when it is perpendicular to the major axis of the orbit from the sun ?

Solution. Let R be the distance of the earth from the sun in the position perpendicular to the major axis of its elliptical orbit.

Using the property of an ellipse, we can write

$$\frac{1}{R} + \frac{1}{R} = \frac{1}{r_1} + \frac{1}{r_2}$$

$$\text{or} \quad \frac{2}{R} = \frac{r_1 + r_2}{r_1 r_2}$$

$$\therefore R = \frac{2r_1 r_2}{r_1 + r_2}$$

Problem 65. Why does the weight of a body become zero at the centre of the earth ? [Himachal 06]

Solution. As we go inside the earth, the value of attracting mass M decreases and its value becomes zero at the centre of the earth. Consequently, a body at the centre of the earth feels no gravitational attraction or its weight becomes zero at the centre of the earth.

Problem 66. Imagine a spacecraft going from the earth to the moon. How does its weight vary as it goes from the earth to the moon ? [Himachal 07C]

Solution.

- As the spacecraft moves from the earth towards the moon, its weight decreases.
- The weight of the spacecraft becomes zero at the null point where the gravitational forces of the earth and the moon are equal and opposite.
- Again the weight increases, becoming $mg/6$ on the moon's surface.

Problem 67. The artificial satellite does not have any fuel, but even then it remains in its orbit around the earth. Why. [Himachal 05]

Solution. The centripetal force necessary for orbital motion of the satellite is provided by the force of gravitation exerted by the earth on the satellite. So the satellite does not need any fuel for its orbital motion.

Problem 68. According to Albert Einstein, no particle can have velocity equal to or greater than that of light. Hence what may be the value of escape velocity from the surface of a 'Black hole' such that it holds everything to itself ? [Central Schools 08]

$$\text{Ans. } v_e = \sqrt{\frac{2GM}{R}} \leq c.$$

Short Answer Conceptual Problems

Problem 1. Answer the following :

- Among the known types of forces in nature, the gravitational force is the weakest. Why then does it play a dominant role for motion of bodies on the terrestrial, astronomical and cosmological scale ?

- Do the forces of friction and other contact forces arise due to gravitational attraction ? If not, what is the origin of these forces ?

Solution. (a) The strong nuclear forces operate only over a range of distance of the order of 10^{-14} to 10^{-15} m. The

forces involved in weak interactions operate only during radioactive decay. Electrical forces are stronger than gravitational forces for a given distance, but they can be attractive as well as repulsive unlike gravitational force, which is always attractive. As a result, the forces between massive neutral bodies are predominantly gravitational.

(b) No, the forces of friction and other contact forces have electromagnetic origin.

Problem 2. Choose the correct alternatives :

- (i) If the gravitational potential energy of two mass points infinite distance away is taken to be zero, the gravitational potential energy of a galaxy is (positive/negative/zero).
- (ii) The universe on the large scale is shaped by (gravitational/electromagnetic forces), on the atomic scale by (gravitational/electromagnetic) forces, on the nuclear scale by (gravitational / electromagnetic/strong nuclear) forces.

Solution. (i) The gravitational potential energy of a galaxy is negative because it is a bound system.

(ii) The universe on the large scale is shaped by gravitational forces, on the atomic scale by *electromagnetic forces* and on the nuclear scale by *strong nuclear forces*.

Problem 3. What is the difference between inertial mass and gravitational mass of a body ?

Solution. The inertial mass of a body is a measure of its inertia and is given by the ratio of the external force applied on it to the acceleration produced in it. The gravitational mass of a body, on the other hand, is a measure of the gravitational pull acting on it due to the earth. The gravitational mass is measured by a common balance.

Problem 4. Which of the following observations point to the equivalence of inertial and gravitational mass :

- (a) Two spheres of different masses dropped from the top of a long evacuated tube reach the bottom of the tube at the same time.
- (b) The time-period of a simple pendulum is independent of its mass.
- (c) The gravitational force on a particle inside a hollow isolated sphere is zero.
- (d) For a man in closed cabin that is falling freely under gravity, gravity 'disappears'.
- (e) An astronaut inside a spaceship orbiting around the Earth feels weightless.
- (f) Planets orbiting around the sun obey Kepler's Third Law (approximately).
- (g) The gravitational force on a body due to the Earth is equal and opposite to the gravitational force on the Earth due to the body. [NCERT]

Solution. The observations (a), (b), (d), (e) and (f) point to the equivalence of gravitational masses, because in these situations the bodies are in motion.

The observations (c) and (g) do not establish the equivalence of inertial and gravitational masses because the bodies are not in the state of motion.

Problem 5. A body is taken from the centre of the earth to the moon. What will be the changes in the weight of the body ?

Solution. (i) At the centre of the earth, the weight of the body is zero ($g = 0$).

(ii) As the body is moved from centre to the earth surface, its weight increases (due to increase in g)

(iii) As the body is moved from earth's surface towards the moon, the weight decreases (due to the decrease in g), becomes zero at the point where the gravitational forces of the earth and moon are equal and opposite.

(iv) Again the weight increases, becoming $mg/6$ on the moon's surface.

Problem 6. Mention the conditions under which the weight of a person can become zero.

Solution. The weight of a person can become zero under the following conditions :

- (i) When the person is at the centre of the earth (as $g = 0$ at the centre of the earth).
- (ii) When the person is at the null points in space (At these points, the gravitational forces due to different masses cancel out).
- (iii) When the person is standing in a freely falling lift.
- (iv) When the person is inside a spacecraft which is orbiting around the earth.

Problem 7. How will the value of g be affected if (i) the rotation of the earth stops (ii) the rotational speed of the earth is doubled (iii) the rotational speed of the earth is increased to seventeen times its present value ?

Solution. (i) If the rotation of the earth stops, no centrifugal force will act on the bodies lying on it. The value of g increases maximum at the equator. As no centrifugal force acts on body at poles, so the value g is not affected.

(ii) If the rotational speed of the earth is doubled, the centrifugal force on the bodies increases. The value of g decreases maximum at the equator and is not affected at poles.

(iii) If the rotational speed of the earth is increased to seventeen times its present value, the value of g at the equator will become zero. At the poles, the value of g remains unchanged.

Problem 8. When a satellite moves to a lower orbit in the atmosphere of the earth, it becomes hot. This indicates that there is some dissipation in its mechanical energy. But the satellite spirals down towards the earth with an increasing speed, why ?

Solution. For a satellite orbiting the earth,

$$\text{Total energy} = - \text{Kinetic energy} \quad \text{i.e., } E = - K$$

When the satellite enters the atmosphere of the earth, it dissipates its mechanical energy (which is negative) against atmospheric friction. Energy E becomes more negative. As a result, the kinetic energy of the satellite increases and hence its speed increases. But its orbital speed $v_0 = \sqrt{GM/(R+h)}$ can increase only if its height h becomes smaller. Hence the satellite moves to a lower orbit with an increased speed. Thus due to the atmospheric friction, the satellite spirals down towards the earth with increasing speed and ultimately burns out in the lower dense atmosphere.

Problem 9. What are the conditions under which a rocket fired from the earth becomes a satellite of the earth and orbits in a circle ?

Solution. (i) First the rocket should be given a sufficient vertical velocity so that it reaches a height at which it is supposed to revolve around the earth.

(ii) At this height, the rocket must be given a horizontal orbital velocity given by $v_0 = \sqrt{\frac{GM}{R+h}}$

(iii) The air resistance should be negligible at the height of its orbit.

Problem 10. What would happen if the force of gravity were to disappear suddenly ?

Solution. If the force of gravity suddenly disappears, then

- (i) All bodies will lose weight.
- (ii) We would be thrown away from the earth due to the centrifugal force.
- (iii) Eating, drinking and in fact all operations would become impossible.
- (iv) Motion of satellites around the planets and the motion of planets around the sun would cease.

Problem 11. The radii of two planets are R and $2R$ respectively and their densities ρ and $\rho/2$ respectively. What is the ratio of acceleration due to gravity at their surfaces ?

[Central Schools 05]

Solution. Here,

$$g = \frac{GM}{R^2} = \frac{G}{R^2} \cdot \frac{4}{3} \pi R^3 \rho = \frac{4}{3} \pi GR\rho$$

$$\text{or } g \propto R\rho$$

$$\therefore \frac{g_1}{g_2} = \frac{R\rho}{2R \cdot \frac{\rho}{2}} = 1:1$$

Problem 12. The time period of the satellite of the earth is 5 hours. If the separation between the earth and the satellite is increased to 4 times the previous value, then what will be the new time period of the satellite ?

[AIEEE 03]

Solution. According to Kepler's law of periods,

$$\left(\frac{T_2}{T_1}\right)^2 = \left(\frac{R_2}{R_1}\right)^3 \quad \text{or} \quad \left(\frac{T_2}{5}\right)^2 = \left(\frac{4R_1}{R_1}\right)^3$$

$$\text{or } T_2 = \sqrt{64 \times 25} = 40 \text{ h.}$$

Problem 13. Prove that acceleration due to gravity on the surface of the earth is given by $g = \frac{4}{3} \pi \rho GR$, where G is gravitational constant, ρ is mean density and R is the radius of the earth.

[Delhi 01, 05C]

Solution. Mass of the earth, $M = \frac{4}{3} \pi R^3 \rho$

Acceleration due to gravity on the earth's surface,

$$g = \frac{GM}{R^2} = \frac{G}{R^2} \times \frac{4}{3} \pi R^3 \rho = \frac{4}{3} \pi \rho GR.$$

Problem 14. Why is the weight of a body at the poles more than the weight at the equator ? Explain.

[Himachal 03 ; Delhi 05C]

Solution. As $g = GM/R^2$ and the value of R at the poles is less than that at the equator, so g at poles is greater than g at the equator. Now, as $g_p > g_e$, hence $mg_p > mg_e$ i.e., the weight of a body at the poles is more than the weight at the equator.

Problem 15. Why does the earth impart the same acceleration to all bodies ?

[Chandigarh 02]

Solution. The force of gravitation exerted by the earth on a body of mass m is

$$F = G \frac{Mm}{R^2} = mg$$

Acceleration imparted to the body,

$$g = \frac{GM}{R^2}$$

Clearly, g does not depend on m . Hence the earth imparts same acceleration to all bodies.

Problem 16. If suddenly the gravitational force of attraction between the earth and a satellite revolving around it becomes zero, what will happen to the satellite ?

[AIEEE 02]

Solution. If the gravitational force of the earth suddenly becomes zero, the satellite will stop revolving around the earth and it will move in a direction tangential to its original orbit with a speed with which it was revolving around the earth.

HOTS

Problems on Higher Order Thinking Skills

Problem 1. Draw graphs showing the variation of acceleration due to gravity with (i) height above the earth's surface and (ii) depth below the earth's surface.

Solution. (i) The value of g varies with height h as

$$g \propto \frac{1}{(R+h)^2} \quad \text{or} \quad g \propto \frac{1}{r^2}$$

Thus the graph of g versus r is the parabolic curve AB , as shown in Fig. 8.42.

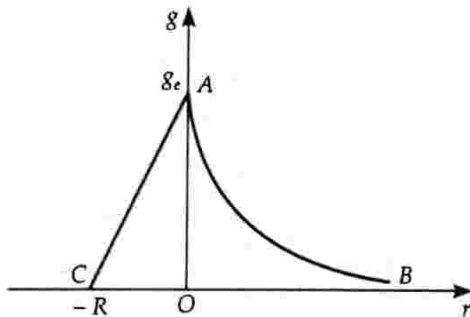

Fig. 8.42

(ii) The value of g varies with depth d as

$$g = g \left(1 - \frac{d}{R}\right) \quad \text{i.e., } g \propto (R-d)$$

Thus the graph of g versus depth d is the straight line AC , as shown in Fig. 8.42.

Problem 2. Are we living at the bottom of a gravitational well? Give reason.

Solution. Yes, we are living at the bottom of a gravitational well. Fig. 8.43 shows the variation of gravitational force F with distance r from the centre of the earth. Clearly, the graph has a force minimum at the surface of the earth ($r = R$).

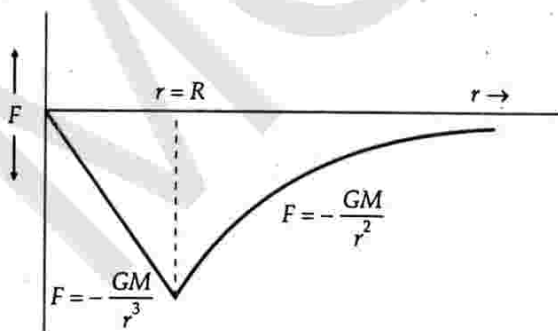

Fig. 8.43

Problem 3. Generally the path of a projectile from the earth is parabolic but it is elliptical for projectiles going to a very great height. Why?

Solution. Under ordinary heights, the change in the distance of a projectile from the centre of the earth is negligible compared to the radius of the earth. Hence the projectile moves under a nearly uniform gravitational force and its path is parabolic. But for projectile going to a very great height, the gravitational force decreases in inverse proportion to the square of the distance of the projectile from the centre of the earth. Under such a variable force, the path of projectile is elliptical.

Problem 4. A person sitting in a satellite feels weightlessness but a person standing on moon has weight though moon is also a satellite of the earth. Give reason.

Solution. For the person sitting in the artificial satellite, the gravitational attraction on him due to the earth provides the necessary centripetal force. The net force on him is zero, so he feels weightlessness. For the person standing on the moon, the gravitational attraction acting on him due to the moon is left unbalanced, which accounts for his weight on the moon.

Problem 5. The sun attracts all bodies on the earth. At midnight, when the sun is directly below, it pulls on a body in the same direction as the pull of the earth on that body; at noon, when the sun is directly above, it pulls on a body in a direction opposite to the pull of the earth. Then will the weight of the body be greater at mid-night than at noon?

Solution. No, earth is a satellite of sun. Any body placed on earth is also the satellite of sun. The body and the earth both will have the same acceleration towards the sun. Hence there will be no relative sun's gravitational acceleration between the body and the earth. That is, a body placed on earth will experience no gravitational effect due to the sun. It will experience a gravitational force only due to the earth. This will be weight of the body measured on the earth and will remain same for all the twenty four hours.

Problem 6. Suppose the gravitational force varies inversely as the n th power of distance. Then, find the expression for the time period of a planet in a circular orbit of radius r around the sun. [AIEEE 04]

Solution. As the gravitational force varies inversely as the n th power of the distance, so the gravitational force on the planet is given by

$$F = \frac{GMm}{r^n}$$

This force provides the centripetal force $m\omega^2 r$ to the planet.

$$\therefore \frac{GMm}{r^n} = m r \omega^2 = m r \left(\frac{2\pi}{T} \right)^2$$

$$\text{or } T^2 = \frac{r \times 4\pi^2 \times r^n}{GM} = \frac{4\pi^2 r^{(n+1)}}{GM}$$

$$\text{or } T = \frac{2\pi}{\sqrt{GM}} r^{(n+1)/2}$$

$$\text{Clearly, } T \propto r^{(n+1)/2}$$

Problem 7. A simple pendulum has a time period T_1 when on the earth's surface, and T_2 when taken to a height R above the earth's surface, where R is the radius of the earth. What is the value of T_2/T_1 ? [IIT Screening 01]

Solution. Let g and g' be the acceleration due to gravity on the earth's surface and at a height R above the earth's surface respectively. Then

$$g' = \frac{g}{\left(1 + \frac{h}{R}\right)^2} = \frac{g}{\left(1 + \frac{R}{R}\right)^2} = \frac{g}{4}$$

Time period of simple pendulum,

$$T = 2\pi \sqrt{\frac{l}{g}}$$

$$\therefore \frac{T_2}{T_1} = \sqrt{\frac{g}{g'}} = \sqrt{\frac{g}{g/4}} = 2.$$

Problem 8. A geo-stationary satellite orbits around the earth in a circular orbit of radius 36,000 km. Then, what will be the time period of a spy satellite orbiting a few hundred km above the earth's surface ($R_{\text{earth}} = 6,400$ km)? [IIT Screening 02]

Solution. As $T^2 \propto R^3$ and $R_e = 6400$ km, therefore

$$\frac{T^2}{(24)^2} = \left(\frac{6400}{36000}\right)^3 \quad \text{or } T = 1.7 \text{ h.}$$

For the spy satellite, R is slightly greater than R_e .

So $T_s > T$ or $T_s \approx 2$ h.

Problem 9. Find the period of oscillation of a simple pendulum of length L suspended from the roof of a vehicle which moves without friction down an inclined plane of inclination α . [IIT Screening 2K]

Solution. The effective value of acceleration due to gravity,

$$g' = g \cos \alpha$$

$$\therefore T = 2\pi \sqrt{\frac{l}{g'}} = 2\pi \sqrt{\frac{l}{g \cos \alpha}}$$

Problem 10. Two bodies of masses m_1 and m_2 are initially at rest placed infinite distance apart. They are then allowed to move towards each other under mutual gravitational

attraction. Show that their relative velocity of approach at separation r between them is

$$v = \sqrt{\frac{2G(m_1 + m_2)}{r}}$$

[BHU 94]

Solution. By conservation of energy,

K.E. of first body = Its gravitation P.E.

$$\frac{1}{2} m_1 v_1^2 = \frac{Gm_1 m_2}{r}$$

$$\text{or } v_1 = \sqrt{\frac{2Gm_2}{r}}$$

$$\text{Similarly, } v_2 = \sqrt{\frac{2Gm_1}{r}}$$

\therefore Relative velocity of approach

$$\begin{aligned} &= v_1 + v_2 = \sqrt{\frac{2Gm_2}{r}} + \sqrt{\frac{2Gm_1}{r}} \\ &= \sqrt{\frac{2G(m_1 + m_2)}{r}} \end{aligned}$$

Problem 11. Imagine a light planet revolving around a massive star in a circular orbit of radius r with a period of revolution T . If the gravitational force of attraction between planet and the star is proportional to $r^{-5/2}$, then find the relation between T and r . [IIT 89]

Solution. Force of gravitation on the planet

= Centripetal force

$$k r^{-5/2} = m r \omega^2 = m r \left(\frac{2\pi}{T} \right)^2$$

$$\text{or } T^2 = \frac{4\pi^2 m r}{k r^{-5/2}} = \frac{4\pi^2 m}{k} r^{7/2}$$

$$\therefore T^2 \propto r^{7/2}.$$

Problem 12. A spherical cavity is made inside a sphere of density ρ . If its centre lies at a distance l from the centre of the sphere, show that the gravitational field strength of the field inside the cavity is

$$E = \frac{4\pi}{3} G l \rho.$$

[Roorkee 86]

Solution. In Fig. 8.44, the gravitational field strength at the centre C of the cavity will be due to the mass of the shaded solid sphere of radius $OC = l$.

Mass of the shaded sphere,

$$M = \frac{4}{3} \pi l^3 \rho$$

Gravitational field strength at the centre C of the cavity is

$$E = \frac{GM}{l^2} = \frac{G}{l^2} \times \frac{4}{3} \pi l^3 \rho$$

$$= \frac{4}{3} \pi G l \rho.$$

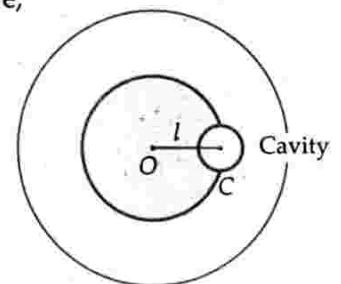

Fig. 8.44

Problem 13. The distance between the centres of two stars is $10a$. The masses of these stars are M and $16M$ and their radii a and $2a$ respectively. A body of mass m is fired straight from the surface of the larger star towards the smaller star. What should be its minimum initial speed to reach the surface of the smaller star? Obtain the expression in terms of G , M and a . [IIT 96]

Solution. Let the gravitational field due to the two stars be zero at some point O lying at a distance x from the centre of smaller star.

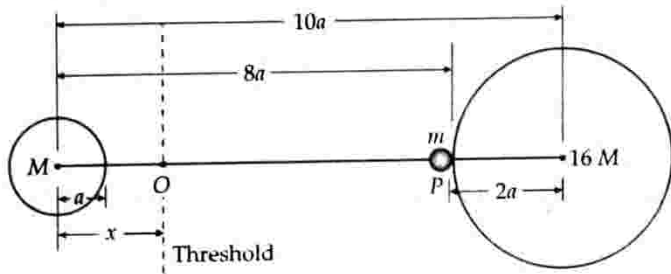

Fig. 8.45

Then

$$G \frac{Mm}{x^2} = G \frac{(16M)m}{(10a-x)^2}$$

$$\text{or } \frac{1}{x^2} = \frac{16}{(10a-x)^2}$$

$$\text{or } 16x^2 = (10a-x)^2$$

$$\text{or } 4x = \pm(10a-x)$$

The negative sign is inadmissible, so $x = 2a$

The body of mass m when fired from point P lying on the surface of heavier star must cross the threshold (the point O), otherwise it would return back.

The gravitational potential energies when the body of mass m lies at positions P and O are given by

$$U_P = -\frac{GMm}{8a} - \frac{G \times 16M \times m}{2a} = -\frac{65GMm}{8a}$$

$$U_O = -\frac{GMm}{2a} - \frac{G \times 16M \times m}{8a} = -\frac{5GMm}{2a}$$

\therefore Increase in potential energy,

$$\Delta U = U_P - U_O = -\frac{5GMm}{2a} + \frac{65GMm}{8a} = \frac{45GMm}{8a}$$

If v is the minimum speed with which the body is fired from P so as to reach O , then

$$\frac{1}{2}mv^2 = \Delta U = \frac{45GMm}{8a}$$

$$\text{or } v = \sqrt{\frac{45GM}{4a}} = \frac{3}{2}\sqrt{\frac{5GM}{a}}$$

Problem 14. An artificial satellite is moving in a circular orbit around the earth with a speed equal to half the

magnitude of escape velocity from the earth. (i) Determine the height of the satellite above the earth's surface. (ii) If the satellite is stopped suddenly in its orbit and allowed to fall freely on to the earth, find the speed with which it hits the surface of the earth. Take $g = 98 \text{ ms}^{-2}$, radius of the earth = 6400 km . [IIT 90]

Solution. (i) Orbital velocity of a satellite at a height h above the earth's surface is

$$v_0 = \frac{GM}{R+h}$$

Escape velocity from the earth's surface,

$$v_e = \sqrt{\frac{2GM}{R}}$$

$$\text{Given } v_0 = \frac{v_e}{2}$$

$$\therefore \sqrt{\frac{GM}{R+h}} = \frac{1}{2} \sqrt{\frac{2GM}{R}}$$

$$\text{or } \frac{GM}{R+h} = \frac{1}{4} \times \frac{2GM}{R} = \frac{GM}{2R}$$

$$\text{or } h = R = 6.4 \times 10^6 \text{ m.}$$

(ii) Let V be the speed with which the satellite hits the earth when suddenly stopped. If m be the mass of the satellite, then by the conservation of energy,

Initial P.E. at height $h (= R)$

= Final P.E. on the surface of earth
+ K.E. of the satellite.

$$\text{or } -\frac{GMm}{2R} = -\frac{GMm}{R} + \frac{1}{2}mV^2$$

$$\text{or } V = \sqrt{\frac{GM}{R}} = \sqrt{\frac{gR^2}{R}} = \sqrt{gR}$$

$$= \sqrt{98 \times 6.4 \times 10^6}$$

$$= 792 \times 10^3 \text{ ms}^{-1} = 7.92 \text{ kms}^{-1}.$$

Problem 15. A particle is projected upward from the surface of the earth (radius R) with a K.E. equal to half the minimum value needed for it to escape. To which height does it rise above the surface of the earth? [IIT 97]

Solution. For the particle to escape, K.E. = P.E.

$$\frac{1}{2}mv_e^2 = \frac{GMm}{R}$$

$$\text{But supplied K.E.} = \frac{1}{2} \times \frac{1}{2} mv_e^2 = \frac{GMm}{2R}$$

Suppose the particle rises to a height h , then

$$\frac{1}{2} \times \frac{1}{2} mv_e^2 = \frac{GMm}{R+h}$$

$$\text{or } \frac{GMm}{2R} = \frac{GMm}{R+h}$$

$$\therefore h = R$$

Guidelines to NCERT Exercises

8.1. Answer the following :

(a) You can shield a charge from electrical forces by putting it inside a hollow conductor. Can you shield a body from the gravitational influence of nearby matter by putting it inside a hollow sphere or by some other means ?

[Central Schools 08]

(b) An astronaut inside a small space ship orbiting around the earth cannot detect gravity. If the space station orbiting around the Earth has a large size, can he hope to detect gravity ?

(c) If you compare the gravitational force on the Earth due to the Sun to that due to the moon, you would find that the Sun's pull is greater than the moon's pull. However, the tidal effect of the moon's pull is greater than the tidal effect of Sun. Why ?

Ans. (a) No. The shell does not shield other bodies lying outside it from exerting gravitational forces on a particle lying inside it.

(b) Yes. If the size of spaceship orbiting around the earth is large enough, the astronaut inside the spaceship can detect the variation in g .

(c) The tidal effect depends inversely upon the cube of the distance whereas the gravitational force varies inversely as the square of the distance. As the moon is closer to earth than the sun, so its tidal effect is greater than that of the sun. The ratio of these two effects is

$$\frac{T_m}{T_s} = \left(\frac{d_s}{d_m}\right)^3 = \left(\frac{1.5 \times 10^{11}}{3.8 \times 10^8}\right)^3 = 61.5 \times 10^6.$$

8.2. Choose the correct alternative :

(i) Acceleration due to gravity increases/decreases with increasing altitude.

(ii) Acceleration due to gravity increases/decreases with increasing depth (assume the Earth to be a sphere of uniform density).

(iii) The effect of rotation on the effective value of acceleration due to gravity is greatest at the equator/poles.

(iv) Acceleration due to gravity is independent of mass of the Earth/mass of the body.

(v) The formula $-GMm(1/r_2 - 1/r_1)$ is more/less accurate than the formula $mg(r_2 - r_1)$ for the difference of potential energy between two points r_2 and r_1 distance away from the centre of the Earth.

Ans. (i) At altitude h , $g_h = g \left(1 - \frac{2h}{R}\right)$.

Thus acceleration due to gravity decreases with increasing altitude.

(ii) At depth d , $g_d = g \left(1 - \frac{d}{R}\right)$

Thus acceleration due to gravity decreases with increasing depth.

(iii) At latitude λ , $g_\lambda = g \left(1 - \frac{R\omega^2 \cos^2 \lambda}{g}\right)$

For maximum variation (decrease) of g , $\cos \lambda = 1$ or $\lambda = 0^\circ$.

Thus the effect of rotation on the effective value g is greatest at the equator (for which $\lambda = 0^\circ$.)

(iv) As $g = \frac{GM}{R^2}$, where M is the mass of the earth.

Thus acceleration due to gravity is independent of mass m of the body.

(v) The formula $-GMm \left(\frac{1}{r_2} - \frac{1}{r_1}\right)$ is more accurate than

the formula $mg(r_2 - r_1)$, because the value of g varies from place to place.

8.3. Suppose there existed a planet that went around the sun twice as fast as the earth. What would be its orbital size as compared to that of the earth ?

Ans. Let period of revolution of the earth

$$= T_e$$

\therefore Period of revolution of planet,

$$T_p = \frac{1}{2} T_e \quad [\because \text{The planet goes around the sun twice as fast as earth}]$$

Orbital size of the earth, $r_e = 1 \text{ AU}$

Orbital size of the planet, $r_p = ?$

From Kepler's third law of planetary motion

$$\frac{T_p^2}{T_e^2} = \frac{r_p^3}{r_e^3}$$

$$\therefore r_p = \left(\frac{T_p}{T_e}\right)^{2/3} r_e = \left(\frac{1}{2} \frac{T_e}{T_e}\right)^{2/3} \times 1 \text{ AU}$$

$$= (0.5)^{2/3} \text{ AU} = 0.63 \text{ AU}.$$

8.4. I_0 , one of the satellites of Jupiter, has an orbital period of 1.769 days and the radius of the orbit is $4.22 \times 10^8 \text{ m}$. Show that the mass of Jupiter is about one thousandth that of the sun.

Ans. Orbital period of Jupiter's satellite,

$$T = 1.769 \text{ days} = 1.769 \times 24 \times 60 \times 60 \text{ s}$$

Orbital radius of Jupiter's satellite,

$$R = 4.22 \times 10^8 \text{ m}$$

Mass of Jupiter is given by

$$M_J = \frac{4\pi^2}{G} \cdot \frac{R^3}{T^2} = \frac{4\pi^2}{G} \cdot \frac{(4.22 \times 10^8)^3}{(1.769 \times 24 \times 60 \times 60)^2}$$

Orbital period of the earth around the sun,

$$T = 1 \text{ year} = 365.25 \times 24 \times 60 \times 60 \text{ s}$$

Orbital radius of the earth,

$$R = 1.496 \times 10^{11} \text{ m}$$

Mass of the sun,

$$M_S = \frac{4\pi^2}{G} \cdot \frac{(1.496 \times 10^{11})^3}{(365.25 \times 24 \times 60 \times 60)^2}$$

$$\begin{aligned} \therefore \frac{M_J}{M_S} &= \frac{(4.22 \times 10^8)^3}{(1.769 \times 24 \times 60 \times 60)^2} \times \frac{(365.25 \times 24 \times 60 \times 60)^2}{(1.496 \times 10^{11})^3} \\ &= \frac{1}{1046} \approx \frac{1}{1000} \end{aligned}$$

Hence the mass of Jupiter is about one thousandth that of the sun.

8.5. Let us assume that our galaxy consists of 2.5×10^{11} stars each of one solar mass. How long will a star at a distance of 50,000 ly from the galactic centre take to complete one revolution? Take the diameter of the milky way to be 10^5 ly.

Ans. Mass of galaxy,

$$\begin{aligned} M &= 2.5 \times 10^{11} \text{ solar masses} \\ &= 2.5 \times 10^{11} \times 2 \times 10^{30} \text{ kg} = 5 \times 10^{41} \text{ kg} \end{aligned}$$

Orbital radius of the star,

$$\begin{aligned} R &= 50,000 \text{ ly} = 50,000 \times 9.46 \times 10^{15} \text{ m} \\ &= 4.73 \times 10^{20} \text{ m} \end{aligned}$$

$$\text{As } M = \frac{4\pi^2}{G} \cdot \frac{R^3}{T^2}$$

$$\therefore T^2 = \frac{4\pi^2}{G} \cdot \frac{R^3}{M} = \frac{4 \times 9.87 \times (4.73 \times 10^{20})^3}{6.67 \times 10^{-11} \times 5 \times 10^{41}}$$

$$= 1.25275 \times 10^{32}$$

$$\therefore T = 1.12 \times 10^{16} \text{ s} = \frac{1.12 \times 10^{16}}{365.25 \times 24 \times 60 \times 60} \text{ years}$$

$$= 3.54 \times 10^8 \text{ years.}$$

8.6. Choose the correct alternatives :

- (a) If the zero of potential energy is at infinity, the total energy of an orbiting satellite is negative of its kinetic/potential energy.
- (b) The energy required to rocket an orbiting satellite out of Earth's gravitational influence is more/less than the energy required to project a stationary object at the same height (as the satellite) out of the Earth's influence.

Ans. (a) The total energy of an orbiting satellite is negative of its kinetic energy.

(b) The energy required to rocket an orbiting satellite out of Earth's gravitational influence is less than the energy required to project a stationary object at the same height out of Earth's influence.

8.7. Does the escape speed of a body from the Earth depend on (a) the mass of the body, (b) the location from where it is projected, (c) the direction of projection, (d) the height of the location from where the body is launched? Explain your answer.

$$\text{Ans. Escape velocity, } v_e = \sqrt{\frac{2GM}{r}}$$

(a) Escape velocity is independent of the mass m of the body to be projected.

(b) As the gravitational potential, $V = GM/R$ depends slightly on the latitude of the point, so escape velocity also depends (slightly) on the latitude of the location from where the body is projected.

(c) Escape velocity is independent of the direction of projection.

(d) As the gravitational potential depends on the height of location, so escape velocity also depends on height of location.

8.8. A comet orbits the sun in a highly elliptical orbit. Does the comet have a constant (a) linear speed, (b) angular speed, (c) angular momentum, (d) kinetic energy, (e) potential energy, (f) total energy throughout its orbit? Neglect any mass loss of the comet when it comes very close to the sun.

Ans. (a) According to Kepler's second law of planetary motion, a planet moves faster when it is close to the sun and moves slower, when away from the sun. So its linear speed keeps on changing.

(b) As the planet moves under the influence of a purely radial force, its angular momentum remains constant.

(c) As the linear speed of the planet continuously changes, so its kinetic energy also keeps on changing.

(d) As the distance of the planet from the sun continuously changes, so its potential energy keeps on changing.

(e) Total energy of the planet always remains constant.

8.9. Which of the following symptoms is likely to afflict an astronaut in space (a) swollen feet, (b) swollen face, (c) headache, (d) orientational problem.

Ans. (b), (c) and (d) are affected in space.

In the following two exercises, choose the correct answer from among the given ones :

8.10. The gravitation intensity at the centre C of the drumhead defined by a hemispherical shell has the direction indicated by the arrow [see Fig. 8.46]

- (i) a, (ii) b, (iii) c, (iv) zero.

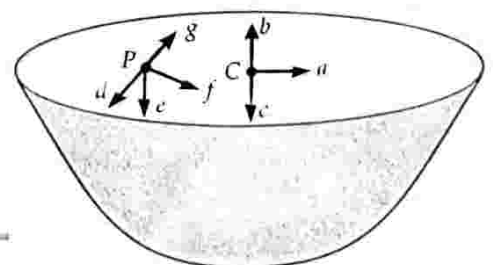

Fig. 8.46

Ans. Complete the hemisphere to sphere, as shown in Fig. 8.47. Gravitational potential V is a constant. So gravitational intensity $\left(E = -\frac{dV}{dr}\right)$ is zero at C (for the complete sphere). For the hemisphere, the net gravitational intensity will point along (c) at the centre C .

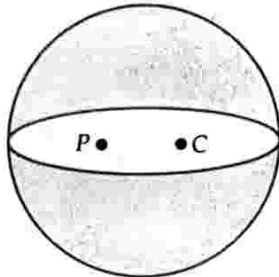

Fig. 8.47

8.11. For the above problem, the direction of the gravitational intensity at an arbitrary point P is indicated by the arrow (i) d , (ii) e , (iii) f , (iv) g .

Ans. By the similar reasoning as in the above problem, the direction of gravitational intensity at P will be along (e) .

8.12. A rocket is fired from the earth towards the sun. At what point on its path is the gravitational force on the rocket zero? Mass of sun = 2×10^{30} kg, mass of the earth = 6×10^{24} kg. Neglect the effect of other planets etc. Orbital radius = 1.5×10^{11} m.

Ans. Given $M_s = 2 \times 10^{30}$ kg,

$$M_e = 6 \times 10^{24} \text{ kg}, r = 1.5 \times 10^{11} \text{ m}$$

Let m be the mass of the rocket. Let at distance x from the earth, the gravitational force on the rocket be zero. Then at this distance,

$$\begin{aligned} \text{Gravitational pull of the earth on the rocket} \\ = \text{Gravitational pull of the sun on the rocket} \end{aligned}$$

$$\text{i.e., } \frac{GM_e m}{x^2} = \frac{GM_s m}{(r-x)^2}$$

$$\text{or } \frac{(r-x)^2}{x^2} = \frac{M_s}{M_e}$$

$$\text{or } \frac{r-x}{x} = \sqrt{\frac{M_s}{M_e}} = \sqrt{\frac{2 \times 10^{30}}{6 \times 10^{24}}} = \frac{10^3}{\sqrt{3}} = 577.35$$

$$\text{or } r-x = 577.35 x$$

$$\text{or } 578.35 x = r = 1.5 \times 10^{11}$$

$$\text{or } x = \frac{1.5 \times 10^{11}}{578.35} = 2.59 \times 10^8 \text{ m.}$$

8.13. How would you 'weigh the sun', that is estimate its mass? The mean orbital radius of the earth around the sun is 1.5×10^8 km.

Ans. Refer to the solution of Example 4 on page 8.6.

8.14. A Saturn year is 29.5 times the earth year. How far is the Saturn from the sun if the earth is 1.50×10^8 km away from the sun?

Ans. According to Kepler's law of periods,

$$\left[\frac{T_S}{T_E}\right]^2 = \left[\frac{r_S}{r_E}\right]^3$$

$$\text{But } \frac{T_S}{T_E} = 29.5 \text{ and } r_E = 1.5 \times 10^8 \text{ km}$$

$$\therefore (29.5)^2 = \left(\frac{r_S}{1.5 \times 10^8}\right)^3$$

$$\text{or } r_S = 1.5 \times 10^8 \times (29.5)^{2/3} = 14.32 \times 10^8 \text{ km.}$$

8.15. A body weighs 63 N on the surface of the earth. What is the gravitational force on it due to the earth at a height equal to half the radius of the earth?

Ans. Here $mg = 63$ N, $h = R/2$

$$\text{As } \frac{g_h}{g} = \left(\frac{R}{R+h}\right)^2 = \left(\frac{R}{R+\frac{R}{2}}\right)^2 = \left(\frac{2}{3}\right)^2 = \frac{4}{9}$$

$$g_h = \frac{4}{9} g$$

$$\therefore mg_h = \frac{4}{9} mg = \frac{4}{9} \times 63 = 28 \text{ N.}$$

8.16. Assuming the earth to be a sphere of uniform mass density, how much would a body weigh half way down to the centre of the earth if it weighed 250 N on the surface?

Ans. Here $mg = 250$ N, $d = R/2$

Acceleration due to gravity at depth $d = R/2$, below the earth's surface will be

$$g_d = g \left(1 - \frac{d}{R}\right) = g \left(1 - \frac{R/2}{R}\right) = \frac{g}{2}$$

$$\therefore \text{New weight} = mg_d = \frac{mg}{2} = \frac{250}{2} = 125 \text{ N.}$$

8.17. A rocket is fired vertically with a speed of 5 kms^{-1} from the earth's surface. How far from the earth does the rocket go before returning to the earth? Mass of earth = 6.0×10^{24} kg, mean radius of the earth = 6.4×10^6 m, $G = 6.67 \times 10^{-11} \text{ Nm}^2 \text{ kg}^{-2}$.

Ans. Here $v = 5 \text{ kms}^{-1} = 5000 \text{ ms}^{-1}$,

$$M = 6.0 \times 10^{24} \text{ kg}, R = 6.4 \times 10^6 \text{ m,}$$

$$G = 6.67 \times 10^{-11} \text{ Nm}^2 \text{ kg}^{-2}.$$

Suppose the rocket goes upto a height h before returning to the earth. Clearly at this height, velocity of rocket will become zero. By the law of conservation of energy,

(K.E. + P.E.) at the earth's surface

= (K.E. + P.E.) at height h

$$\text{or } \frac{1}{2} mv^2 - \frac{GMm}{R} = 0 - \frac{GMm}{(R+h)}$$

$$\begin{aligned} \text{or } v^2 - \frac{2GM}{R} &= -\frac{2GM}{R+h} \\ \text{or } \frac{2GM}{R+h} &= \frac{2GM}{R} - v^2 = \frac{2GM - v^2 R}{R} \\ \text{or } R+h &= \frac{2GMR}{2GM - v^2 R} \\ &= \frac{2 \times 6.67 \times 10^{-11} \times 6.0 \times 10^{24} \times 6.4 \times 10^6}{2 \times 6.67 \times 10^{-11} \times 6.0 \times 10^{24} - (5000)^2 \times 6.4 \times 10^6} \\ &= \frac{5.12 \times 10^{21}}{6.4 \times 10^{14}} = 8.0 \times 10^6 \text{ m} \\ h &= 8.0 \times 10^6 - R = 8.0 \times 10^6 - 6.4 \times 10^6 \\ &= 1.6 \times 10^6 \text{ m.} \end{aligned}$$

8.18. The escape velocity of a projectile on the earth's surface is 11.2 km s^{-1} . A body is projected out with thrice this speed. What is the speed of the body far away from the earth? Ignore the presence of the sun and other planets.

Ans. Escape velocity, $v_c = 11.2 \text{ km s}^{-1}$

Velocity of projection, $v = 3v_c$.

Let m be the mass of projectile and v_0 be the velocity of the projectile after escaping gravitational pull.

By the law of conservation of energy,

$$\frac{1}{2} m v_0^2 = \frac{1}{2} m v^2 - \frac{1}{2} m v_c^2$$

$$\begin{aligned} \text{or } v_0 &= \sqrt{v^2 - v_c^2} = \sqrt{(3v_c)^2 - v_c^2} = \sqrt{8v_c^2} \\ &= \sqrt{8 \times (11.2)^2} = 22.4 \sqrt{2} = 31.68 \text{ km s}^{-1}. \end{aligned}$$

8.19. A satellite orbits the earth at a height of 400 km above the surface. How much energy must be expended to rocket the satellite out of the earth's gravitational influence? Mass of the satellite = 200 kg, mass of the earth = $6.0 \times 10^{24} \text{ kg}$, radius of the earth = $6.4 \times 10^6 \text{ m}$, $G = 6.67 \times 10^{-11} \text{ Nm}^2 \text{ kg}^{-2}$.

Ans. Total energy of the satellite in the orbit is

$$\begin{aligned} E &= \text{K.E.} + \text{P.E.} = \frac{1}{2} m v^2 - \frac{GMm}{R+h} \\ &= \frac{1}{2} m \frac{GM}{R+h} - \frac{GMm}{R+h} = -\frac{GMm}{2(R+h)} \\ &\quad \left[\because v = \sqrt{\frac{GM}{R+h}} \right] \end{aligned}$$

Here $G = 6.67 \times 10^{-11} \text{ Nm}^2 \text{ kg}^{-2}$, $M = 6.0 \times 10^{24} \text{ kg}$

$m = 200 \text{ kg}$, $R = 6.4 \times 10^6 \text{ m}$,

$h = 400 \text{ km} = 400 \times 10^3 \text{ m}$

$$\begin{aligned} \therefore E &= -\frac{6.67 \times 10^{-11} \times 6.0 \times 10^{24} \times 200}{2(6.4 \times 10^6 + 400 \times 10^3)} \\ &= -\frac{6.67 \times 6.0}{6.8} \times 10^9 = -5.89 \times 10^9 \text{ J} \end{aligned}$$

Energy required to rocket the satellite

$$= 5.89 \times 10^9 \text{ J.}$$

8.20. Two stars each of 1 solar mass ($= 2 \times 10^{30} \text{ kg}$) are approaching each other for a head-on collision. When they are at a distance 10^9 km , their speeds are negligible. What is the speed with which they collide? The radius of each star is 10^4 km . Assume the stars to remain undistorted until they collide. Use the known value of G .

Ans. Mass of each star, $M = 2 \times 10^{30} \text{ kg}$

Radius of each star, $R = 10^7 \text{ m}$

Initial P.E. of the two stars when they are 10^{12} m apart,

$$U_i = -\frac{GM \times M}{r} = -\frac{GM^2}{10^{12}} \quad [r = 10^9 \text{ km} = 10^{12} \text{ m}]$$

When the stars are just to collide, distance between their centres

$$= \text{twice the radius of each star} = 2R = 2 \times 10^7 \text{ m}$$

Final P.E. of the two stars when they just collide,

$$U_f = -\frac{GM \times M}{2R} = -\frac{GM^2}{2 \times 10^7}$$

Change in P.E. of the stars

$$\begin{aligned} &= U_i - U_f = -\frac{GM^2}{10^{12}} - \left(-\frac{GM^2}{2 \times 10^7} \right) \\ &= \frac{GM^2}{2 \times 10^7} - \frac{GM^2}{10^{12}} = \frac{GM^2}{2 \times 10^7} \quad \left[\because \frac{GM^2}{10^{12}} \ll \frac{GM^2}{2 \times 10^7} \right] \end{aligned}$$

Let v be the velocity of each star just before collision. Then

Change in K.E. of the stars

$$= \text{Final K.E.} - \text{Initial K.E.}$$

$$= 2 \times \frac{1}{2} Mv^2 - 0 = Mv^2$$

By conservation of energy,

$$Mv^2 = \frac{GM^2}{2 \times 10^7}$$

$$\begin{aligned} \text{or } v &= \sqrt{\frac{GM}{2 \times 10^7}} = \sqrt{\frac{6.67 \times 10^{-11} \times 2 \times 10^{30}}{2 \times 10^7}} \\ &= 2.6 \times 10^6 \text{ ms}^{-1}. \end{aligned}$$

8.21. Two heavy spheres each of mass 100 kg and radius 0.1 m are placed 1.0 m apart on a horizontal table. What is the gravitational field and potential at the mid point of the line joining the centres of the spheres?

Take $G = 6.67 \times 10^{-11} \text{ Nm}^2 \text{ kg}^{-2}$.

Ans. Let A and B be the positions of the two spheres and P be the midpoint of AB.

Gravitational field at P due to mass at A,

$$E_1 = \frac{GM}{r^2} = \frac{G \times 100}{(0.5)^2}, \text{ along PA}$$

Gravitational field at P due to mass at B,

$$E_2 = \frac{G \times 100}{(0.5)^2}, \text{ along PB}$$

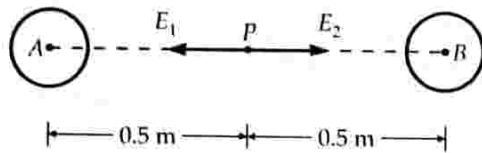

Fig. 8.48

As E_1 and E_2 have equal magnitudes but opposite directions, so the resultant gravitational field at P is zero.

As gravitational potential is a scalar quantity, so total potential at P is

$$V = V_A + V_B = -\frac{GM}{r} - \frac{GM}{r} = -\frac{2GM}{r}$$

$$= -\frac{2 \times 6.67 \times 10^{-11} \times 100}{0.5} = -2.668 \times 10^{-8} \text{ J kg}^{-1}.$$

8.22. A geostationary satellite orbits the earth at a height of nearly 36,000 km from the surface of the earth. What is the potential due to earth's gravity at the site of the satellite? Mass of the earth = 6×10^{24} kg and radius = 6400 km.

Ans. Here $M = 6 \times 10^{24}$ kg, $R = 6400$ km,
 $h = 36,000$ km

$$r = R + h = 6400 + 36,000 = 42,400 \text{ km} = 4.24 \times 10^7 \text{ m}$$

Gravitational potential,

$$V = -\frac{GM}{r} = -\frac{6.67 \times 10^{-11} \times 6 \times 10^{24}}{4.24 \times 10^7}$$

$$= -9.43 \times 10^6 \text{ J kg}^{-1}.$$

8.23. A star 2.5 times the mass of the sun and collapsed to a size of 12 km rotates with a speed of 1.5 rev/s. Will an object placed on its equator remain stuck to its surface due to gravity? Mass of the sun = 2×10^{30} kg.

Ans. Here $M = 2.5 \times \text{Mass of the sun}$
 $= 2.5 \times 2 \times 10^{30} = 5 \times 10^{30}$ kg
 $R = 12 \text{ km} = 12 \times 10^3 \text{ m}$

Acceleration due to gravity on the surface of the star is

$$g = \frac{GM}{R^2} = \frac{6.67 \times 10^{-11} \times 5 \times 10^{30}}{(12 \times 10^3)^2} = 2.316 \times 10^{12} \text{ ms}^{-2}$$

Now $v = 1.5$ rps, so $\omega = 2\pi v = 3\pi \text{ rad s}^{-1}$

Centripetal acceleration of the object = $R\omega^2$

$$= 12 \times 10^3 \times (3 \times 3.14)^2 = 1.065 \times 10^6 \text{ ms}^{-2}$$

As the acceleration due to gravity on the surface of the star is greater than the centripetal acceleration of the object, so the object will remain stuck to its surface.

8.24. A spaceship is stationed on Mars. How much energy must be expended on the spaceship to rocket it out of the solar system? Mass of the spaceship 1000 kg, mass of the sun = 2×10^{30} kg, mass of Mars = 6.4×10^{23} kg, radius of Mars 3395 km, radius of the orbit of Mars = 2.28×10^8 km, $G = 6.67 \times 10^{-11} \text{ Nm}^2 \text{ kg}^{-2}$.

Ans. Energy of the spaceship in the orbit is

$$E = \text{K.E.} + \text{P.E.} = \frac{1}{2} mv^2 - \frac{GMm}{(R+h)}$$

$$= \frac{1}{2} m \cdot \frac{GM}{R+h} - \frac{GMm}{R+h} \quad \left[\because v = \sqrt{\frac{GM}{R+h}} \right]$$

$$= -\frac{GMm}{2(R+h)}$$

But $m = 1000$ kg, $G = 6.67 \times 10^{-11} \text{ Nm}^2 \text{ kg}^{-2}$,

$$M = 2 \times 10^{30} \text{ kg}$$

$$R = 2.28 \times 10^8 \text{ km} = 2.28 \times 10^8 \times 10^3 \text{ m,}$$

$$h = 3395 \text{ km} = 3395 \times 10^3 \text{ m}$$

$$\therefore E = -\frac{6.67 \times 10^{-11} \times 2 \times 10^{30} \times 1000}{2(2.28 \times 10^8 \times 10^3 + 3395 \times 10^3)}$$

$$= -2.9 \times 10^{11} \text{ J.}$$

Energy needed to rocket the spaceship out of solar system = 2.9×10^{11} J.

8.25. A rocket is fired vertically from the surface of Mars with a speed of 2 kms^{-1} . If 20% of its initial energy is lost due to Martian atmospheric resistance, how far will the rocket go from the surface of Mars before returning to it? Mass of Mars = 6.4×10^{23} kg, radius of Mars = 3395 km, $G = 6.67 \times 10^{-11} \text{ Nm}^2 \text{ kg}^{-2}$.

Ans. Total energy of the rocket

$$E = \frac{1}{2} mv^2 - \frac{GMm}{R}$$

Since 20% energy is lost, hence energy remained

$$= 80\% \text{ or } E = \frac{80}{100} E = \frac{4}{5} E = \frac{4}{5} \left[\frac{1}{2} mv^2 - \frac{GMm}{R} \right].$$

At the highest point, distant h from the surface of Mars, its total energy will be potential. Hence

$$\frac{4}{5} \left[\frac{1}{2} mv^2 - \frac{GMm}{R} \right] = -\frac{GMm}{R+h}$$

$$\text{or } \frac{2}{5} m \left(v^2 - \frac{2GM}{R} \right) = -\frac{GMm}{R+h}$$

$$\text{or } \frac{2}{5} \cdot \frac{v^2 R - 2GM}{R} = -\frac{GM}{R+h}$$

$$\text{or } R+h = -\frac{5RGM}{2(v^2 R - 2GM)}$$

But $R = 3395 \text{ km} = 3395 \times 10^3 \text{ m,}$

$$G = 6.67 \times 10^{-11} \text{ Nm}^2 \text{ kg}^{-2}$$

$$M = 6.4 \times 10^{23} \text{ kg, } v = 2 \text{ kms}^{-1} = 2 \times 10^3 \text{ ms}^{-1}$$

$$\therefore R+h = -\frac{5 \times 3395 \times 10^3 \times 6.67 \times 10^{-11} \times 6.4 \times 10^{23}}{2[(2 \times 10^3)^2 \times 3395 \times 10^3 - 2 \times 6.67 \times 10^{-11} \times 6.4 \times 10^{23}]}$$

$$= -\frac{7.25 \times 10^{20}}{2[1.36 \times 10^{13} - 8.54 \times 10^{13}]}$$

$$= \frac{7.25 \times 10^7}{2 \times 7.18} = 5.05 \times 10^6 \text{ m}$$

$$\text{or } h = 5.05 \times 10^6 - 3395 \times 10^3$$

$$= 1655 \times 10^3 \text{ m} = 1655 \text{ km.}$$

Text Based Exercises

Type A : Very Short Answer Questions

1 Mark Each

- What is difference between gravitation and gravity ?
- What do you mean by free fall of a body ?
- State Newton's law of gravitation. [Delhi 05]
- Does the force of attraction between two bodies depend upon the presence of other bodies and properties of intervening medium ?
- The value of G on the surface of earth is $6.67 \times 10^{-11} \text{ Nm}^2 \text{ kg}^{-2}$. What is its value on the moon ?
- What are the dimensions of gravitational constant? [Delhi 97, 05C]
- Do all the bodies fall with the same constant acceleration in the absence of air resistance ?
- What are the values of g and G at the centre of the earth ?
- Give one point of difference between g and G .
- Which is scalar and which is vector amongst g and G ?
- Name the scientist who first determined the value of G experimentally.
- Name the apparatus used for the experimental determination of G .
- Do the gravitational forces obey Newton's third law of motion ?
- The gravitational force between two bodies is 1 N. If the distance between them is doubled, what will be the force ? [Himachal 06]
- Does the acceleration with which a body falls towards the centre of the earth depend on mass of the body ?
- Calculate the force of attraction between two balls each of mass 1 kg when their centres are 10 cm apart. The value of gravitational constant $G = 6.67 \times 10^{-11} \text{ Nm}^2 \text{ kg}^{-2}$. [Delhi 97]
- The distance of Pluto from the sun is 40 times the distance of earth. If the masses of earth and Pluto be equal, what will be ratio of gravitational forces of sun on these planets ?
- Write an expression for the acceleration due to gravity on the earth's surface.
- Write an equation for the mean density of the earth.
- The gravitational force acting on a rocket at a height h from the earth's surface is $1/3$ rd of the force acting on a body at sea level. What is relation between h and R_e (radius of the earth) ?
- The mass and diameter of a planet are twice those of the earth. What will be acceleration due to gravity at the planet, if acceleration due to gravity on the earth is g ?
- What is the mass of a body that weighs 1 N at a place where $g = 9.80 \text{ ms}^{-2}$? [Delhi 97]
- How much is the torque due to gravity on a body about its centre of mass ?
- Which is greater – the attraction of earth for 1 kg of iron or attraction of 1 kg of iron for the earth ? Give reason.
- Has gravity any effect on inertial mass ?
- Why do different planets have different escape velocities ?
- On what factors does the value of g depend ?
- What is the effect of altitude on acceleration due to gravity ?
- What is the effect of non-sphericity of the earth on the value of ' g ' ? [Delhi 03]
- If accelerations due to gravity at a height h and at a depth d below the surface of the earth are equal, how are h and d related ?
- How does the weight of a body vary enroute from the earth to the moon ? Would its inertial mass change and gravitational mass change ?
- What is the time period of a simple pendulum at the centre of the earth ?
- What will be our weight at the centre of earth, if the earth were a hollow sphere ?
- A body of mass 5 kg is taken to the centre of the earth. What will be its mass there ?
- If a man goes from the surface of the earth to a height equal to the radius of the earth, then what will be his weight relative to that on the earth ? What if he goes equally below the surface of the earth ?

36. The earth is acted upon by the gravitational force of attraction due to the sun. Then why does the earth not fall towards the sun ?
37. Suppose the earth stops rotating about its axis. What will be the effect on the weight of bodies ?
38. If the earth rotates faster, how does g change at poles ?
39. What is the effect on our weight due to revolution of the earth about the sun ?
40. Write the formula for the gravitational potential energy of mass m at a finite distance r in the gravitational field of mass M .
41. What is the work done in bringing a body of mass m from infinity to the surface of the earth ?
42. What is the unit of intensity of the gravitational field ?
43. What is the value of gravitational potential energy at infinity ?
44. What is the value of the gravitational intensity at the earth's surface and at the earth's centre ?
45. What is the relation between gravitational intensity and gravitational potential at a point ?
46. Why is gravitational potential energy negative ?
47. The gravitational potential energy of a body at a distance r from the centre of the earth is U . What is the weight of the body at that point ?
48. From where does a satellite get centripetal force for moving around its planet ?
49. What is escape velocity ? Write down its minimum value on the surface of the earth ?
50. Define orbital velocity of a satellite.
51. How does the orbital velocity of a satellite depend on the mass of the satellite ? [Delhi 04]
52. A satellite revolves close to the surface of a planet. How is its orbital velocity related with velocity of escape from that planet ? [Chandigarh 07]
53. What are the values of the escape velocities for the moon and the sun respectively ?
54. Which has greater value of escape velocity-Mercury or Jupiter ?
55. Does the escape velocity of a body depend upon the density of a planet ?
56. Why does hydrogen escape from the earth's atmosphere more readily than oxygen ?
57. Does the speed of a satellite remain constant in an orbit ?
58. The speed of revolution of an artificial satellite revolving close to the surface of the earth is 8 kms^{-1} . What will be the escape velocity for a body on the earth ? [Manipur 99]
59. A satellite revolving around the earth loses height. What happens to its time period ?
60. If the kinetic energy of a satellite revolving in an orbit close to the earth's surface happens to be doubled, will the satellite escape ?
61. The escape velocity on earth is 11.2 kms^{-1} . What will be its value on a planet having double the radius and eight times the mass of the earth ?
62. What is Geosynchronous satellite ? [Delhi 95]
63. What is a parking orbit ?
64. What is the use of stationary orbit ?
65. What is (i) period of revolution and (ii) sense of rotation of a geostationary satellite ? [Himachal 06]
66. The centripetal force on a satellite revolving around the earth is F .
(i) What is the gravitational force due to earth on it ?
(ii) What is the net force on it ?
67. What is the angular velocity of a geostationary satellite in radian per hour ?
68. A spring balance is suspended inside an artificial satellite revolving around the earth. If a body of mass 1 kg is suspended from it, what would be its reading ?
69. The escape velocity from the earth for a body of 20 g is 11 kms^{-1} . What will be its value for a body of 100 g ?
70. A body lying on the surface of planet Venus has gravitational potential energy equal to $-7.5 \times 10^6 \text{ J}$. How much energy will be required for the body to escape from the planet ?
71. Two artificial satellites are revolving around the earth, one closer to its surface and other away from it. Which has larger speed ?
72. Write two conditions for the existence of atmosphere on a planet. [CBSE(F) 94]
73. Write the most important application of geostationary satellite. [Delhi 02]
74. What would happen to an artificial satellite if its orbital velocity is slightly decreased due to some defects in it ? [Manipur 97]
75. What is the frequency of oscillation of a simple pendulum mounted in a cabin that is freely falling under gravity ? [Delhi 05]

76. What is the basis of Kepler's law of areas of planetary motion ?
77. What is the basis of Newton's law of gravitation ?
78. A simple pendulum is mounted inside a spacecraft. What should be its time period of vibration ?
[Central Schools 05]
79. The gravitational potential energy of a body at a point in a gravitational field of another body is $-\frac{GMm}{r}$. What does the negative sign show ?
[Central Schools 05]
80. What is meant by a geostationary satellite ?
[Himachal 05]
81. What is full form of geostationary satellite APPLE ?
[Himachal 05]
82. What will be the kinetic energy needed to project a body of mass m from the earth's surface (radius R) to infinity ?
[AIEEE 02]
83. What is gravitational force ?
[Himachal 07]
84. Define universal gravitatal constant.
[Himachal 07C]
85. What is the weight of a body at the centre of the earth ?
[Himachal 05C]
86. Where does the body weigh more – at the surface of the earth or in a mine ?
[Himachal 05C]
87. If the change in the value of 'g' at a height 'h' above the surface of earth is same as that at a depth 'x' below it (both x and h being much smaller than radius of earth), then how are x and h related to each other ?
[Chandigarh 07]
88. How would the value of 'g' change if the earth were to shrink slightly without any change in mass ?
[Central Schools 09]
89. If the radius of the earth shrinks by 1 percent, its mass remaining the same by what percentage will the acceleration due to gravity on its surface change ?
[Central Schools 09]
90. The distances of two planets from the sun are 10^{11} m and 10^{10} m respectively. What is the ratio of time period of these two planets ?
[Central Schools 09]
91. Name India's first cosmonaut.
[Himachal 05]
92. What is weightlessness ?
[Himachal 07, 07C]
93. Give two uses of geostationary satellites.
94. Give two uses of polar satellites.
95. What are the time period and height of a geostationary satellite above the surface of the earth ?
[Central Schools 12]

Answers

- Gravitation is the force of attraction between any two bodies in the universe while gravity refers to the force of attraction between any body and the earth.
- The motion of a body under the influence of gravity alone is called a free fall.
- Refer to point 2 of Glimpses.
- No, $F = \frac{G m_1 m_2}{r^2}$ is independent of the presence of other bodies and properties of intervening medium.
- G is a universal constant, so its value on the moon = $6.67 \times 10^{-11} \text{ Nm}^2 \text{ kg}^{-2}$.
- $[G] = [M^{-1}L^3T^{-2}]$.
- Yes, this acceleration is called acceleration due to gravity.
- At the centre of the earth g is zero, while $G = 6.67 \times 10^{-11} \text{ Nm}^2 \text{ kg}^{-2}$.
- While the value of g varies from place to place, the value of G remains the same throughout the universe.
- g is a vector and G is a scalar.
- Lord Cavendish.
- Cavendish's torsion balance.
- Yes, they obey Newton's third law of motion.
- 0.25 N, because $F \propto 1/r^2$.
- No, acceleration due to gravity is independent of the mass of the body.
- $F = G \frac{m_1 m_2}{r^2} = \frac{6.67 \times 10^{-11} \times 1 \times 1}{0.10} = 6.67 \times 10^{-10} \text{ N}$.
- $\frac{F_{es}}{F_{ps}} = \left(\frac{r_{ps}}{r_{es}}\right)^2 = \left(\frac{40}{1}\right)^2 = 1600:1$.
- $g = \frac{GM_e}{R_e^2}$.
- $\rho = \frac{3g}{4\pi GR}$.
- Given $\frac{GM_e m}{(R_e + h)^2} = \frac{1}{3} \frac{GM_e m}{R_e^2}$
 $\therefore R_e + h = \sqrt{3} R_e = 1.732 R_e$
or $h = 0.732 R_e$.

21. As $g = \frac{GM}{R^2}$
 $\therefore g' = \frac{G(2M)}{(2R)^2} = \frac{1}{2} \frac{GM}{R^2} = \frac{g}{2}$.
22. $m = \frac{W}{g} = \frac{1}{9.80} = 0.102 \text{ kg}$.
23. Zero.
24. The two bodies interact gravitationally due to their masses, so they exert equal forces on each other but in opposite directions.
25. No.
26. Different planets have different escape velocities ($v_e = \sqrt{2GM/R}$) because of their different masses and sizes.
27. The value of g depends on (i) the shape of the earth (ii) latitude (iii) altitude (iv) depth.
28. Acceleration due to gravity decreases with altitude.
29. The acceleration due to gravity is minimum at the equator and gradually increases from equator to poles.
30. $d = 2h$.
31. When taken from earth to moon, the weight of a body gradually decreases to zero. It then increases till at the moon's surface, it becomes $mg/6$. However, its inertial and gravitational masses remain unchanged.
32. At the centre of the earth, $g = 0$.
 $\therefore T = 2\pi \sqrt{\frac{l}{g}} = \infty$.
 Hence the pendulum does not oscillate at all.
33. Zero, because the intensity of a gravitational field inside a hollow sphere is zero.
34. The mass of the body will remain 5 kg at the centre of the earth because it remains the same at all places.
35. (i) $\frac{g_h}{g} = \frac{R^2}{(R+h)^2} = \frac{R^2}{(R+R)^2} = \frac{1}{4}$
 $\therefore mg_h = \frac{1}{4} mg$ i.e., weight becomes one-fourth.
 (ii) $mg_d = mg \left(1 - \frac{d}{R}\right) = m \left(1 - \frac{R}{R}\right) = 0$.
36. The gravitational attraction of the sun provides the centripetal force to keep the earth in stable orbit around the earth.
37. The weight of the bodies will increase.
38. The value of g does not change.
39. No effect.
40. $-GMm/r$.
41. GMm/r .
42. $N\text{kg}^{-1}$.
43. Zero.
44. 9.8 N kg^{-1} , zero.
45. Gravitational intensity at a point is equal to the negative of the potential gradient at that point.
46. Because it arises due to attractive forces of gravitation.
47. $U = \frac{GMm}{r} = \left(\frac{GM}{r^2}\right) rm = grm = mg \times r$.
 \therefore Weight of the body $= mg = U/r$.
48. The gravitational force of attraction exerted by the planet provides the necessary centripetal force to the satellite.
49. Escape velocity is defined as the minimum velocity with which a body must be thrown vertically upwards in order that it may just escape the gravitational pull of the earth. Its value on the earth's surface is 11.2 km s^{-1} .
50. Orbital velocity is the velocity given to an artificial earth's satellite a few hundred kilometers above the earth's surface so that it may start revolving around the earth.
51. $v_0 = \sqrt{\frac{GM}{R+h}}$.
 Clearly, orbital velocity does not depend on mass of a satellite.
52. $v_c = \sqrt{2} v_0$.
53. $v_{\text{moon}} = 2.4 \text{ kms}^{-1}$ and $v_{\text{sun}} = 620 \text{ kms}^{-1}$.
54. Jupiter.
55. Yes, $v_p \propto \sqrt{p}$.
56. This is because the r.m.s. speed of hydrogen molecules is four times that of oxygen molecules.
57. As $v_0 = \sqrt{\frac{GM}{r}}$. For a particular orbit r is constant, so v_0 remains constant.
58. $v_c = \sqrt{2}v_0 = \sqrt{2} \times 8 = 11.3 \text{ kms}^{-1}$.
59. Time period of a satellite,

$$T = 2\pi \sqrt{\frac{(R+h)^3}{GM}}$$
.
 Clearly when h decreases, T also decreases.
60. Yes, when the K.E. of the satellite is doubled, its orbital velocity increases $\sqrt{2}$ times and becomes equal to the escape velocity. So the satellite will escape.

61. $\frac{v_p}{v_e} = \sqrt{\frac{2GM_p}{R_p}} \times \sqrt{\frac{R_e}{2GM_e}} = \sqrt{\frac{M_p}{M_e}} \times \frac{R_e}{R_p} = \sqrt{8 \times \frac{1}{2}} = 2$
 $\therefore v_p = 2v_e = 2 \times 11.2 = 22.4 \text{ kms}^{-1}$.
62. A satellite which revolves around earth with the same angular speed and in the same direction as the earth rotates about its own axis is called geosynchronous satellite.
63. The orbit of a geostationary satellite is called parking orbit. It lies in the equatorial plane at a height of about 36,000 km from the earth's surface.
64. By means of satellites in stationary orbits, television programmes can be transmitted continuously from one part of the world to the other parts.
65. (i) 24 hours (ii) west to east.
66. (i) F (ii) F.
67. $\omega = \frac{2\pi \text{ rad}}{24 \text{ h}} = \frac{\pi}{12} \text{ rad h}^{-1}$.
68. Zero, because the satellite is in a state of free fall.
69. 11.2 kms^{-1} , because the escape velocity does not depend on the mass of the body projected.
70. $+7.5 \times 10^6 \text{ J}$.
71. Orbital speed of a satellite revolving at height h is

$$v_0 = \sqrt{\frac{GM}{R+h}}$$
 Clearly smaller the height h , larger is the orbital speed v_0 . Hence the satellite revolving closer to the earth's surface has larger speed v_0 .
72. The two conditions for the existence of atmosphere on a planet are
 (a) High value of acceleration due to gravity on the planet.
 (b) Low surface temperature of the planet.
73. A geostationary satellite can be used to communicate radio, T.V. and telephone signals between any two points of the earth.
74. The satellite will fall to the earth.
75. In a freely falling cabin, $g = 0$.

$$v = \frac{1}{2\pi} \sqrt{\frac{g}{l}} = 0$$
 Hence the pendulum will not oscillate.
76. Kepler's law of areas is based on the law of conservation of angular momentum.
77. Kepler's laws of planetary motion.
78. A body is in a state of weightlessness inside a spacecraft *i.e.*, $g = 0$
 $\therefore T = 2\pi \sqrt{\frac{l}{g}} = \infty$.
79. The negative sign shows that the gravitational potential energy of one body is due to the attractive gravitational force exerted by the other body.
80. Refer to point 24 of Glimpses.
81. Ariana Passenger Pay Load Experiment.
82. Required kinetic energy

$$= \frac{1}{2} m \times (\text{escape velocity})^2$$

$$= \frac{1}{2} m (\sqrt{2gR})^2$$

$$= mgR$$
.
83. The force of attraction between two bodies by virtue of their masses is called gravitational force.
84. The universal gravitational constant may be defined as the force of attraction between two bodies of unit mass each and placed unit distance apart.
85. Zero, because the value of g is zero at the centre of the earth.
86. At the surface of the earth, because weight decreases with depth.
87. $h = 2x$.
88. The value of ' g ' slightly increases.
89. The value of ' g ' increases by 2%.
90. $\frac{T_1}{T_2} = \left(\frac{r_1}{r_2}\right)^{3/2} = \left(\frac{10^{11}}{10^{10}}\right)^{3/2} = 10^{3/2} = 10\sqrt{10}$.
91. Rakesh Sharma.
92. Refer to point 28 of Glimpses.
93. Refer answer to Q.46 on page 8.35.
94. Refer answer to Q.47 on page 8.35.
95. $T = 24 \text{ h}$ and $h = 36,000 \text{ km}$.

Type B : Short Answer Questions

2 or 3 Marks Each

- State Newton's law of gravitation. Hence define universal gravitational constant. Give the value and dimensions of G . [Meghalaya 96, 99 ; Himachal 07]
- State the universal law of gravitation. Establish the relationship $M_e = gR_e^2 / G$, where M_e and R_e are the mass and radius of the earth respectively. [Delhi 02]

3. Define acceleration due to gravity. Show that the value of 'g' decreases with altitude or height.
[Meghalaya 96 ; Himachal 02, 04, 05, 07]
4. Derive an expression for g (acceleration due to gravity) at a depth d from the surface of earth. Consider the earth as a sphere of uniform mass density. What happens to 'g' at the centre of earth.
[Chandigarh 03 ; Delhi 12]
5. Define acceleration due to gravity. Show that gravity decreases with depth.
[Himachal 05, 06 ; Central Schools 09]
6. Discuss the variation of 'g' (i) with altitude (ii) with depth (iii) with latitude : Rotation of earth.
[Central Schools 04, 05 ; Delhi 06]
7. Explain the variation of 'g' with (i) shape of earth ; (ii) rotation of earth and prove that the weight of body remains unchanged at the poles of earth.
[Chandigarh 03]
8. Show that the acceleration due to gravity at a height h above the surface of the earth has same value as that at depth $d = 2h$ below the surface of the earth.
9. Write the definitions and expressions of the intensity of gravitational field and gravitational potential. State their SI units. [Himachal 04]
10. Write down the formula of gravitational potential energy and obtain from it an expression for gravitational potential.
11. Define the term gravitational field. Show that acceleration due to gravity is equal to the intensity of gravitational field at any point.
12. Define gravitational potential. Give its SI unit.
[Delhi 10, 11]
13. What do you mean by gravitational potential energy of a body ? Obtain an expression for it for a body of mass m lying at distance r from the centre of the earth. [Chandigarh 08 ; Delhi 08, 10]
14. (i) What is meant by gravitational field strength ?
(ii) Which of the planets of the solar-system has the greatest gravitational field strength ?
(iii) What is the gravitational field strength of a planet where the weight of a 60 kg astronaut is 300 N ? [Delhi 97, 05]
15. What is the maximum value of potential energy that can be possessed by a heavenly body ? Give the general expression for potential energy of an object near the surface of earth. [Central Schools 03]
16. Define Escape Velocity. Derive an expression for escape velocity of an object from the surface of a planet. [Delhi 99, 03C, Himachal 02, 03, 05]
17. (i) Define escape velocity.
(ii) Derive expression for the escape velocity of an object from the surface of a planet.
(iii) Does it depend on location from where it is projected ? [Delhi 09]
18. Derive an expression for the escape velocity of a satellite projected from the surface of the earth. [Central Schools 07]
19. What is escape velocity ? Prove that escape velocity from the surface of earth is 11.2 kms^{-1} .
[Himachal 07C ; Delhi 95]
20. What happens to a body when it is projected vertically upwards from the surface of the earth with a speed of 11200 m/s , and why ? Compare escape speeds for two planets of masses M and $4M$ and radii $2R$ and R respectively. [Delhi 2003]
21. A black hole is a body from whose surface nothing may ever escape. What is the condition for a uniform spherical mass M to be a black hole ? What should be the radius of such a black hole if its mass is the same as that of the earth ? [Delhi 03C]
22. Define the term orbital speed. Establish a relation for orbital speed of a satellite orbiting very close to the surface of the earth. Find the ratio of this orbital speed and escape speed. [Delhi 05]
23. What are geostationary satellites ? Calculate the height of the orbit above the surface of the earth in which a satellite, if placed, will appear stationary. [Delhi 02]
24. Find the expression of total energy of a satellite revolving around the surface of earth. What is the significance of negative sign in the expression ?
[Chandigarh 07 ; Central Schools 08]
25. State and explain Kepler's laws of planetary motion. Name the physical quantities which remain constant during the planetary motion.
[Central Schools 01, 07 ; Delhi 11, 12]
26. State and derive Kepler's law of areas.
27. State and derive Kepler's law of periods (or harmonic law) for circular orbits.
28. (a) According to Kepler's second law, the radius vector to a planet from the sun sweeps out equal areas in equal interval of time. The law is consequence of which conservation law ?
(b) State Kepler's third law. [Delhi 09]
29. (a) State Kepler's third law of periods.
(b) Two satellites are at different heights (smaller and larger) from the surface of earth. Which would have greater velocity ?
(c) What is the formula for escape velocity in terms of g and R ? [Central Schools 08]

30. What is a polar satellite ? Explain how does it scan the entire earth in its each revolution ? Give two important uses of a polar satellite.
31. What do you mean by the term weightlessness ? Explain the state of weightlessness of
(i) a freely falling body
(ii) an astronaut in a satellite orbiting the earth.
32. Distinguish between inertial and gravitational masses, giving an illustration for each. Show that the two types of masses are equivalent.
33. State the conditions necessary for a satellite to appear stationary. [Himachal 07]
34. Define orbital velocity. Derive an expression for it. [Himachal 05C, 07]

Answers

1. Refer answer to Q. 6 on page 8.3.
2. Refer answer to Q. 6 on page 8.3 & Q. 15 on page 8.9.
3. Refer answer to Q. 18 on page 8.13.
4. Refer answer to Q. 19 on page 8.15.
5. Refer answer to Q.19 on page 8.15.
6. Refer to point 12 of Glimpses.
7. Refer to point 12 of Glimpses.
8. Refer answer to Q. 21 on page 8.16.
9. Refer to points 14 and 15 of Glimpses.
10. Refer answer to Q. 35 on page 8.22.
11. Refer answer to Q. 28 and Q. 29 on page 8.20.
12. Refer to point 15 of Glimpses.
13. Refer answer to Q. 32 and Q. 33 on page 8.21.
14. (i) Refer to point 14 of Glimpses.
(ii) The gravitational field strength is maximum on Jupiter.
(iii) Gravitational field strength

$$= \frac{F}{m} = \frac{300}{60} = 5 \text{ Nkg}^{-1}.$$
15. The maximum value of potential energy of a heavenly body is zero. The gravitational P.E. of a body of mass m near the surface of the earth is

$$U = -\frac{GMm}{R}$$
16. Refer answer to Q. 36 on page 8.27.
17. Refer answer to Q.36 on page 8.27. Yes, it depends on height of location from where the satellite is projected.
18. Refer answer to Q.36 on page 8.27.
19. Refer answer to Q. 36 on page 8.27 and solution of Example 36 on page 8.28.
20. The body will escape the gravitational field of the earth.

$$\frac{v_e}{v_e'} = \sqrt{\frac{2GM}{2R}} \cdot \sqrt{\frac{R}{2G \times 4M}} = \frac{1}{\sqrt{8}} = 1 : \sqrt{8}.$$
21. Refer to solution of Example 38 on page 8.28.
22. Refer answer to Q. 41 on page 8.31.
23. Refer answer to Q. 43 on page 8.34.
24. Refer answer to Q.48 on page 8.36.
25. Refer answer to Q. 50 on page 8.38. Total mechanical energy and angular momentum are conserved during planetary motion.
26. Refer answer to Q. 54 on page 8.40.
27. Refer answer to Q. 55 on page 8.40.
28. (a) Law of conservation of angular momentum.
(b) According to Kepler's third law of periods, the square of the period of revolution of a planet around the sun is proportional to the cube of the semimajor axis of its elliptical orbit.
29. (a) Refer answer to part (b) of the above question.
(b) Orbital velocity, $v_0 = \sqrt{\frac{GM}{R+h}}$
Clearly, the satellite revolving at smaller height h from the surface of the earth will have a greater velocity.
(c) $v_e = \sqrt{2gR}.$
30. Refer answer to Q. 47 on page 8.35.
31. Refer answer to Q. 57 on page 8.43.
32. Refer answer to Q. 58 and Q. 59 on page 8.44.
33. Refer answer to Q. 44 on page 8.35.
34. Refer answer to Q.41 on page 8.31.

Type C : Long Answer Questions

5 Marks Each

1. Explain how did Newton discover the universal law of gravitation ?
2. What is meant by acceleration due to gravity ? Obtain an expression for it in terms of mass of the earth and gravitational constant. Explain how the mass and the density of the earth can be obtained from the knowledge of G .

3. What do you mean by acceleration due to gravity ? Discuss the variation of g on the surface of the earth due to axial rotation of the earth. Derive the necessary relation. [Meghalaya 98]
4. Obtain an expression for the acceleration due to gravity on the surface of the earth in terms of mass of the earth and its radius. Discuss the variation of acceleration due to gravity with altitude, depth and rotation of the earth. [Kerala 01]
5. What is escape velocity ? Obtain an expression for the escape velocity on earth. Why is it that there is no atmosphere on the moon ? Explain. [Chandigarh 08]
6. (a) Define Orbital velocity and establish an expression for it.
(b) Calculate the value of orbital velocity for an artificial satellite of earth orbiting at a height of 1000 km.
Given : Mass of earth = 6×10^{24} kg
Radius of earth = 6400 km. [Delhi 96]
7. Define orbital velocity and time period of a satellite. Derive expressions for these. [Himachal 02, 06]
8. State Kepler's laws of planetary motion. Deduce Newton's law of gravitation from Kepler's law. [Himachal 02, 05C, 07C ; Chandigarh 04]

Answers

1. Refer answer to Q. 5 on page 8.2.
2. Refer answer to Q. 15 and 16 on page 8.9.
3. Refer answer to Q. 24 on page 8.18.
4. Refer answer to Q. 15 on page 8.9. Refer to point 12 of Glimpses.
5. Refer answer to Q.36 on page 8.27 and solution of Problem 46 on page 8.49.
6. (a) Refer answer to Q. 41 on page 8.31.
(b) Refer to solution of Example 44 on page 8.32.
7. Refer answer to Q. 41 on page 8.31 and Q. 42 on page 8.32.
8. Refer answer to Q. 50 on page 8.38 and Q. 56 on page 8.40.

Gravitation

GLIMPSES

- 1. Gravitation and gravity.** Gravitation is the force of attraction between any two bodies while gravity refers to the force of attraction between any body and the earth.
- 2. Newton's law of gravitation.** It states that every body in this universe attracts every other body with a force which is directly proportional to the product of their masses and inversely proportional to the square of the distance between them.

$$\text{Mathematically, } F = G \frac{m_1 m_2}{r^2}$$

where G is the universal gravitational constant. It was derived by Newton on the basis of Kepler's laws of planetary motion.

- 3. Universal gravitational constant (G).** It is equal to the force of attraction between two bodies of unit mass each and separated by unit distance.

$$\text{In SI units, } G = 6.67 \times 10^{-11} \text{ Nm}^2 \text{ kg}^{-2}$$

$$\text{In CGS system, } G = 6.67 \times 10^{-8} \text{ dyne cm}^2 \text{ g}^{-2}$$

Dimensional formula of G is $[M^{-1}L^3T^{-2}]$.

- 4. Properties of gravitational forces.** The gravitational force between two point masses (i) is independent of intervening medium (ii) obeys Newton's third law of motion (iii) has spherical symmetry (iv) is independent of the presence of other bodies (v) obeys principle of superposition (vi) is conservative and central.

- 5. Principle of superposition of gravitational forces.** The gravitational force between two masses acts independently and uninfluenced by the presence of other bodies. Hence the resultant force on a particle due to a number of masses is the vector sum of the gravitational forces exerted by the individual masses on the given particle.

$$\vec{F}_R = \vec{F}_1 + \vec{F}_2 + \vec{F}_3 + \dots + \vec{F}_n = \sum_{i=1}^n \vec{F}_i$$

- 6. Shell theorem.** (i) The gravitational force on a particle placed anywhere inside a spherical shell is zero (ii) If a particle lies outside a spherical shell, the shell attracts the particle as though the mass of the shell were concentrated at the centre of the shell.
- 7. Free fall.** The motion of a body under the influence of gravity alone is called a free fall.
- 8. Acceleration due to gravity (g).** The acceleration produced in the motion of a body under the effect of gravity is called acceleration due to gravity.

$$\text{At the surface of the earth, } g = \frac{GM}{R^2}$$

where M is the mass and R the radius of the earth. It is a vector quantity. Its SI unit is ms^{-2} .

- 9. Mass of the earth.** It is given by

$$M = \frac{gR^2}{G}$$

- 10. Mean density of the earth.** If the earth is a sphere of mass M and mean density ρ , then its mass would be

$$M = \text{Volume} \times \text{density} = \frac{4}{3} \pi R^3 \rho$$

$$\text{Also, } M = \frac{gR^2}{G}$$

$$\therefore \frac{4}{3} \pi R^3 \rho = \frac{gR^2}{G}$$

$$\text{or } \rho = \frac{3g}{4\pi GR}$$

- 11. Weight of a body.** It is the gravitational force with which a body is attracted towards the centre of the earth.

$$\vec{W} = m \vec{g}$$

Weight of a body is a vector quantity. It is measured in newton, kg wt, etc. The weight of a body varies from place to place because of the variation in the value of g .

12. Variation of acceleration due to gravity.

(i) **Effect of altitude.** At a height h ,

$$g_h = g \left(1 + \frac{h}{R}\right)^{-2}$$

and $g_h = g \left(1 - \frac{2h}{R}\right)$, when $h \ll R$.

Clearly, the value of g decreases with the increase in h .

(ii) **Effect of depth.** At a depth d ,

$$g_d = g \left(1 - \frac{d}{R}\right)$$

Clearly, the value of g decreases with the increase in depth d and becomes zero at the centre of the earth.

(iii) **Effect of rotation.** If ω is the angular velocity of the earth about its axis of rotation, then at latitude λ ,

$$g_\lambda = g - R\omega^2 \cos^2 \lambda$$

As λ increases, $\cos \lambda$ decreases and g_λ increases. So as we move from equator to pole, the value of g increases.

At equator, $\lambda = 0^\circ$, $\cos \lambda = 1$, hence

$$g_{\text{equa}} = g - R\omega^2$$

At poles, $\lambda = 90^\circ$, $\cos \lambda = 0$

hence $g_{\text{pole}} = g - R\omega^2 \times 0 = g$

Hence g is minimum at equator and maximum at poles.

$$g_{\text{pole}} - g_{\text{equa}} = g - (g - R\omega^2) = R\omega^2.$$

(iv) **Effect of non-sphericity of the earth.** The earth has an equatorial bulge and is flattened at the poles. As $R_e > R_p$, so the value of g is minimum at the equator and maximum at the poles.

13. **Gravitational field.** It is the space around a material body in which its gravitational pull can be experienced by other bodies.

14. **Intensity of gravitational field.** The intensity or strength of gravitational field at any point in a gravitational field is equal to the force experienced by a unit mass placed at that point. It is a vector quantity directed towards the body producing the gravitational field. It is given by

$$E = \frac{\text{Force}}{\text{Mass}} = \frac{F}{m} = \frac{GM}{r^2}$$

The intensity of gravitational field at a point is equal to the acceleration due to gravity at that point.

SI unit of E is N kg^{-1} and the CGS unit is dyne g^{-1} .

15. **Gravitational potential.** The gravitational potential at a point in the gravitational field of a body is the amount of work done in bringing a body of unit mass from infinity to that point. It is a scalar quantity.

$$\text{Gravitational potential, } V = \frac{\text{Work done}}{\text{Mass}} = -\frac{GM}{r}$$

SI unit of V is J kg^{-1} and its CGS unit is erg g^{-1} .

16. **Gravitational potential energy.** The gravitational potential energy of a body may be defined as the energy associated with it due to its position in the gravitational field of another body and is measured by the amount of work done in bringing a body from infinity to a given point in the gravitational field of the other body.

$$\text{Gravitational P.E.} = \text{Gravitational potential} \times \text{mass of body}$$

$$U = -\frac{GM}{r} \times m$$

Gravitational intensity (E) and gravitational potential (V) at a point are related as

$$E = -\frac{dV}{dr}$$

17. **Escape velocity (v_e).** It is the minimum velocity with which a body must be projected vertically upwards in order that it may just escape the gravitational field of the earth.

$$v_e = \sqrt{\frac{2GM}{R}} = \sqrt{2gR}$$

For earth, the value of escape velocity is 11.2 kms^{-1} . It is independent of the mass of body projected.

18. **Satellite.** It is a heavenly or an artificial body which is revolving continuously in an orbit around a planet.

19. **Orbital velocity of a satellite (v_0).** It is the velocity required to put a satellite in its orbit around a planet. The orbital velocity of a satellite revolving around the earth at a height h is given by

$$v_0 = \sqrt{\frac{GM}{R+h}} = \sqrt{\frac{gR^2}{R+h}} = R \sqrt{\frac{g}{R+h}}$$

When a satellite revolves close to the surface of the earth, ($h = 0$),

$$v_0 = \sqrt{gR} \quad \text{and} \quad v_e = \sqrt{2} v_0.$$

20. **Time period of a satellite (T).** It is the time taken by a satellite to go once around the planet

$$T = \frac{\text{Circumference of the orbit}}{\text{Orbital velocity}}$$

$$\begin{aligned}
 &= \frac{2\pi(R+h)}{v_0} = \frac{2\pi(R+h)}{\sqrt{\frac{GM}{R+h}}} \\
 &= 2\pi\sqrt{\frac{(R+h)^3}{GM}} = 2\pi\sqrt{\frac{(R+h)^3}{gR^2}} \\
 &= \sqrt{\frac{3\pi(R+h)^3}{G\rho R^3}}
 \end{aligned}$$

If the satellite revolves just close to the surface of the earth, $h = 0$, then

$$T = 2\pi\sqrt{\frac{R^3}{GM}} = 2\pi\sqrt{\frac{R}{g}} = \sqrt{\frac{3\pi}{G\rho}}$$

21. **Height of a satellite above the earth's surface.** We know that

$$T = 2\pi\sqrt{\frac{(R+h)^3}{gR^2}} \quad \text{or} \quad (R+h)^3 = \frac{T^2 R^2 g}{4\pi^2}$$

$$\text{or} \quad h = \left[\frac{T^2 R^2 g}{4\pi^2} \right]^{1/3} - R$$

22. **Angular momentum of a satellite.** The angular momentum of a satellite of mass m moving with velocity v_0 in an orbit of radius $r (= R + h)$ is given by

$$L = m_0 v r = m \sqrt{\frac{GM}{r}} \cdot r = \sqrt{GMm^2 r}$$

23. **Total energy of a satellite.** For a satellite of mass m moving with velocity v_0 in an orbit of radius r ,

$$\text{Potential energy, } U = -\frac{GMm}{r}$$

$$\text{Kinetic energy, } K = \frac{1}{2} m v_0^2 = \frac{1}{2} m \left(\frac{GM}{r} \right)$$

$$\text{Total energy, } E = K + U$$

$$\text{or} \quad E = \frac{1}{2} m v_0^2 - \frac{GMm}{r} = -\frac{GMm}{2r}$$

$$\text{Clearly, } E = -K = U/2$$

Negative total energy indicates that the satellite is bound to the earth.

24. **Geostationary or synchronous satellite.** It is satellite which revolves around the earth with the same angular speed and in the same direction as the earth rotates about its own axis. Such a satellite should revolve around the earth from west to east in an orbit concentric and coplanar with the equatorial plane of the earth at a height of 36,000 km.

Three geostationary satellites with a mutual angular separation of 120° can be used to communicate between any of two points of the entire earth.

25. **Polar satellite.** A satellite that revolves in a polar orbit is called a polar satellite. Such a satellite passes once over geographical north and south poles during each round trip. A polar orbit has a smaller radius of 500 – 800 km.

26. **Conservation of quantities in motion under gravitational influence.** During the motion of an object under the gravitational influence of another object the following quantities are conserved : (a) Angular momentum (b) Total mechanical energy.

Linear momentum is not conserved. Conservation of angular momentum leads to Kepler's second law of planetary motion.

27. **Kepler's laws of planetary motion**

(i) **Law of orbits.** Every planet moves in an elliptical orbit around the sun, with the sun being at one of the focii.

(ii) **Law of areas.** The radius vector drawn from the sun to the planet sweeps out equal areas in equal intervals of time *i.e.*, the areal velocity of a planet is constant.

(iii) **Law of periods or Harmonic law.** The square of the period of revolution (T) of a planet around the sun is proportional to the cube of the semi-major axis r of the ellipse.

$$T^2 \propto r^3$$

28. **Weightlessness.** A body is said to be in a state of weightlessness when the reaction of the supporting surface is zero or its apparent weight is zero. An astronaut experiences weightlessness in a space satellite. This is not because the gravitational force is small at that location in space. It is because both the astronaut and the satellite are in the state of free fall towards the earth.

29. **Inertial mass.** The mass of a body which measures its inertia and which is given by the ratio of the external force applied on it to the acceleration produced in it along a smooth horizontal surface is called inertial mass.

$$\text{Inertial mass} = \frac{\text{Applied force}}{\text{Acceleration produced}} \quad \text{or} \quad m_i = \frac{F}{a}$$

30. **Gravitational mass.** The mass of a body which determines the gravitational pull due to earth acting upon it is called gravitational mass. On the surface of the earth,

$$F = \frac{GMm_g}{R^2}$$

$$\therefore \text{Gravitational mass, } m_g = \frac{FR^2}{GM}$$

Inertial mass of a body is equivalent to its gravitational mass.

IIT Entrance Exam

MULTIPLE CHOICE QUESTIONS WITH ONE CORRECT ANSWER

1. If the radius of earth were to shrink by one percent (its mass remaining the same), then the acceleration due to gravity on the earth's surface

(a) would decrease (b) would remain unchanged
(c) would increase (d) cannot be predicted

[IIT 81]

2. A simple pendulum has a time period T_1 when on the earth's surface, and T_2 when taken to a height R above the earth's surface, where R is the radius of the earth. The value of T_2/T_1 is

- (a) 1 (b) $\sqrt{2}$
(c) 4 (d) 2

[IIT 01]

3. If the distance between the earth and the sun were half its present value, the number of days in year would have been

- (a) 64.5 (b) 129
(c) 182.5 (d) 730

[IIT 96]

4. A geo-stationary satellite orbits around the earth in a circular orbit of radius 36,000 km. Then, the time period of a spy satellite orbiting a few hundred km above the earth's surface ($R_{earth} = 6,400$ km) will approximately be

- (a) $(\frac{1}{2})$ h (b) 1 h
(c) 2 h (d) 4 h

[IIT 02]

5. A binary star system consists of two stars A and B which have time periods T_A and T_B , radii R_A and R_B and masses M_A and M_B . Then

- (a) if $T_A > T_B$, then $R_A > R_B$
(b) if $T_A > T_B$, then $M_A > M_B$
(c) $\left(\frac{T_A}{T_B}\right)^2 = \left(\frac{R_A}{R_B}\right)^3$ (d) $T_A = T_B$

[IIT 06]

6. A geostationary satellite is orbiting the earth at a height of $6R$ above the surface of the earth, R being the radius of the earth. The time period of another satellite at a height of $2.5R$ from the surface of earth is

- (a) $6\sqrt{2}$ hours (b) 6 hours
(c) $6\sqrt{3}$ hours (d) 10 hours

[IIT 87]

7. If W_1, W_2 and W_3 represent the work done in moving a particle from A to B along three different paths 1, 2 and 3 respectively (as shown in the figure) in

the gravitational field of a point mass m . Find the correct relation between W_1, W_2 and W_3 .

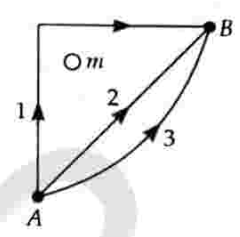

- (a) $W_1 > W_2 > W_3$
(b) $W_1 = W_2 = W_3$
(c) $W_1 < W_2 < W_3$
(d) $W_2 > W_1 > W_3$

[IIT 03]

8. If g is the acceleration due to gravity on the earth's surface, the gain in the potential energy of an object of mass m raised from the surface of the earth to a height equal to the radius R of the earth, is

- (a) $\frac{1}{2} mgR$ (b) $2mgR$
(c) mgR (d) $\frac{1}{4} mgR$

[IIT 83]

9. An artificial satellite moving in a circular orbit around the earth has total (kinetic + potential) energy E_0 . Its potential energy is

- (a) $-E_0$ (b) $1.5 E_0$
(c) $2 E_0$ (d) E_0

[IIT 97]

10. A spherically symmetric system of particles has a mass density

$$\rho = \begin{cases} \rho_0 & \text{for } r \leq R \\ 0 & \text{for } r > R \end{cases}$$

where ρ_0 is a constant. A test mass can undergo circular motion under the influence of the gravitational field of particles. Its speed v as a function of distance r ($0 < r < \infty$) from the centre of the system is represented by

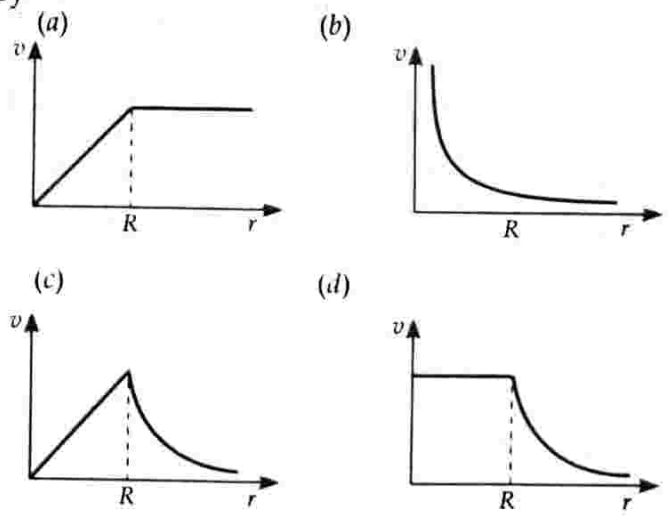

[IIT 08]

11. A thin uniform annular disc (see figure) of mass M has outer radius $4R$ and inner radius $3R$. The work required to take a unit mass from point P on its axis to infinity is

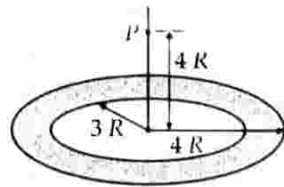

- (a) $\frac{2GM}{7R}(4\sqrt{2}-5)$ (b) $-\frac{2GM}{7R}(4\sqrt{2}-5)$
 (c) $\frac{GM}{4R}$ (d) $\frac{2GM}{5R}(\sqrt{2}-1)$ [IIT 2010]

12. A satellite is moving with a constant speed V in a circular orbit about the earth. An object of mass m is ejected from the satellite such that it just escapes from the gravitational pull of the earth. At the time of its ejection, the kinetic energy of the object is

- (a) $\frac{1}{2}mV^2$ (b) mV^2
 (c) $\frac{3}{2}mV^2$ (d) $2mV^2$ [IIT 2011]

➤ **MULTIPLE CHOICE QUESTIONS WITH ONE OR MORE THAN ONE CORRECT ANSWER**

13. Imagine a light planet revolving around a very massive star in a circular orbit of radius R with a period of revolution T . If the gravitational force of attraction between the planet and the star is proportional to $R^{-5/2}$, then

- (a) T^2 is proportional to R^3
 (b) T^2 is proportional to $R^{7/2}$
 (c) T^2 is proportional to $R^{3/2}$
 (d) T^2 is proportional to $R^{7/3}$. [IIT 89]

14. A solid sphere of uniform density and radius 4 units is located with its centre at the origin O of coordinates. Two spheres of equal radii 1 unit, with

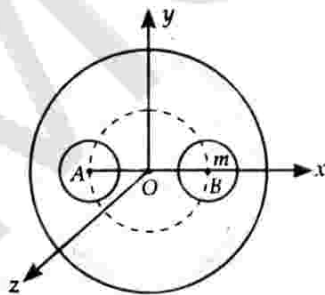

their centres at $A(-2, 0, 0)$ and $B(2, 0, 0)$ respectively, are taken out of the solid leaving behind spherical cavities as shown in the figure. Then

- (a) the gravitational force due to this object at the origin is zero

- (b) the gravitational force at the point $B(2, 0, 0)$ is zero
 (c) the gravitational potential is the same at all points of circle $y^2 + z^2 = 36$
 (d) the gravitational potential is the same at all points of circle $y^2 + z^2 = 4$. [IIT 93]

15. The magnitudes of the gravitational field at distances r_1 and r_2 from the centre of a uniform sphere of radius R and mass m are F_1 and F_2 respectively. Then

- (a) $\frac{F_1}{F_2} = \frac{r_1}{r_2}$, if $r_1 < R$ and $r_2 < R$
 (b) $\frac{F_1}{F_2} = \frac{r_2^2}{r_1^2}$, if $r_1 > R$ and $r_2 > R$
 (c) $\frac{F_1}{F_2} = \frac{r_1}{r_2}$, if $r_1 > R$ and $r_2 > R$
 (d) $\frac{F_1}{F_2} = \frac{r_1^2}{r_2^2}$, if $r_1 < R$ and $r_2 < R$. [IIT 94]

16. A satellite S is moving in an elliptical orbit around the earth. The mass of the satellite is very small compared to the mass of the earth.

- (a) the acceleration of S is always directed towards the centre of the earth
 (b) the angular momentum of S about the centre of the earth changes in direction, but its magnitude remains constant
 (c) the total mechanical energy of S varies periodically with time
 (d) the linear momentum of S remains constant in magnitude. [IIT 98]

➤ **REASONING TYPE**

Instructions. Each question contains statement - 1 (assertion) and statement - 2 (reason). Of these statements mark correct choice if

- (a) statements - 1 and 2 are true and statement - 2 is a correct explanation for statement - 1.
 (b) statements - 1 and 2 are true and statement - 2 is not a correct explanation for statement - 1
 (c) statement - 1 is true, statement - 2 is false
 (d) statement - 1 is false, statement - 2 is true.

17. **Statement 1** : An astronaut in an orbiting space station above the earth experiences weightlessness.

Statement 2 : An object moving around the earth under the influence of earth's gravitational field is in a state of free-fall. [IIT 08]

MATCH MATRIX TYPE

18. Column II shows five systems in which two objects are labelled as X and Y. Also in each case a point P is shown. Column I gives some statements about X and/or Y. Match these statements to the appropriate system(s) from Column II.

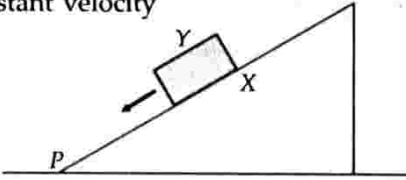
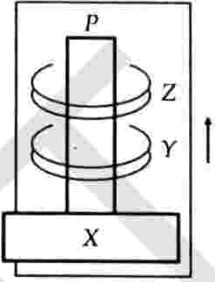
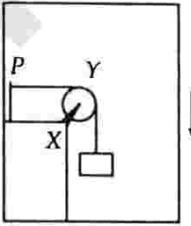
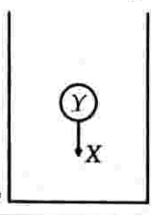
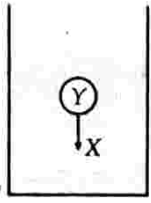
Column I	Column II
(a) The force exerted by on has a magnitude	<p>(p) Block of mass left on a fixed inclined plane , slides on it with a constant velocity</p> 
(b) The gravitational energy of X is continuously increasing	<p>(q) Two ring magnets Y and Z, each of mass M, are kept in frictionless vertical plastic stand so that they repel each other. Y rests on the base X and Z hangs in air in equilibrium. P is the topmost point of the stand on the common axis of the two rings. The whole system is in a lift that is going up with a constant velocity.</p> 
(c) Mechanical energy of the system X + Y is continuously decreasing	<p>(r) A pulley Y of mass m_0 is fixed to a table through a clamp X, a block of mass M hangs from a string that goes over the pulley and is fixed at point P of the table. The whole system down is kept in a lift that is going with a constant velocity</p> 
(d) The torque of the weight of Y about point P is zero	<p>(s) A sphere Y of mass M is put in a nonviscous liquid X kept in a container at rest. The sphere is released and it moves down in the liquid.</p> 
	<p>(t) A sphere Y of mass M is falling with its terminal velocity in a viscous liquid X kept in a container.</p> 

INTERIOR ANSWER TYPE

19. Gravitational acceleration on the surface of a planet is $\frac{\sqrt{6}}{11}g$, where g is the gravitational acceleration on the surface of the earth. The average mass density of

the planet is $\frac{2}{3}$ times that of the earth. If the escape speed on the surface of the earth is taken to be 11 km s^{-1} , find the escape speed on the surface of the planet in km s^{-1} . [IIT 2010]

Answers and Explanations

1. (c) Acceleration due to gravity on earth's surface

$$g = \frac{GM}{R^2}$$

If R decreases, then g increases.

Hence option (c) is correct.

2. (d) On earth surface, $g_1 = \frac{GM}{R}$

At a height equal to R , $g_2 = \frac{GM}{(2R)^2} = \frac{g_1}{4}$

As $T = 2\pi\sqrt{\frac{l}{g}}$ $\therefore \frac{T_2}{T_1} = \sqrt{\frac{g_1}{g_2}} = \sqrt{\frac{g_1}{g_1/4}} = 2$.

3. (b) According to Kepler's law of periods,

$$T^2 \propto R^3$$

$\therefore \left(\frac{T_2}{T_1}\right)^2 = \left(\frac{R_2}{R_1}\right)^3 = \left(\frac{R_1/2}{R_1}\right)^3 = \frac{1}{8}$

$$T_2 = \frac{1}{2\sqrt{2}} \times T_1 = 0.353 \times 365 \text{ days} = 129 \text{ days.}$$

4. (c) For a geostationary satellite,

$$T_1 = 24 \text{ h}, R_1 = 36000 \text{ km}$$

For a satellite on earth's surface,

$$T_2 = ?, R_2 \approx 6400 \text{ km}$$

$$\frac{T_2}{T_1} = \left(\frac{6400}{36000}\right)^3 = \left(\frac{8}{45}\right)^3 = \frac{1}{178}$$

$$T_2 = \frac{T_1}{178} = \frac{24}{13.34} = 1.8 \text{ h.}$$

For a spying satellite slightly above earth's surface,

$$T_2 = 2 \text{ h.}$$

5. (d) The two stars of a binary star system have the same angular velocity.

$$\therefore \omega = \frac{2\pi}{T_A} = \frac{2\pi}{T_B}$$

Hence $T_A = T_B$.

6. (a) For a geostationary satellite,

$$T_1 = 24 \text{ h}, R_1 = 6R + R = 7R$$

For another satellite,

$$T_2 = ?, R_2 = 2.5R + R = 3.5R$$

$$\left(\frac{T_2}{T_1}\right)^2 = \left(\frac{R_2}{R_1}\right)^3 = \left(\frac{3.5R}{7R}\right)^3 = \frac{1}{8}$$

$$T_2 = \frac{1}{2\sqrt{2}} T_1 = \frac{1}{2\sqrt{2}} \times 24 \\ = 6\sqrt{2} \text{ h.}$$

7. (b) Gravitational field is a conservative field. Work done in taking a body from one position to another along different paths in such a field is same.

8. (a) On earth's surface, $U_1 = -\frac{GMm}{R}$

At a height equal to radius of the earth,

$$U_2 = -\frac{GMm}{R+r} = -\frac{GMm}{2R}$$

$$\Delta U = U_2 - U_1 = -\frac{GMm}{2R} + \frac{GMm}{R} \\ = \frac{GMm}{2R}$$

But $g = \frac{GM}{R^2}$

$$\therefore \Delta U = \frac{gR^2 \times m}{2R} = \frac{mgR}{2}$$

9. (c) P.E. of a satellite

$$= 2 \times \text{Total energy} = 2E_0.$$

10. (c) For $r < R$,

$$F = \frac{GMm}{R^3} r = \frac{mv^2}{r}$$

$$\therefore v^2 \propto r^2 \quad \text{or} \quad v \propto r$$

For $r > R$

$$F = \frac{GMm}{r^2} = \frac{mv^2}{r}$$

$$\therefore v \propto \frac{1}{\sqrt{r}}$$

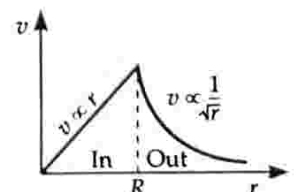

Hence the correct option is (c).

11. (a) The mass of annular ring of thickness dx and radius x is

$$dM = \frac{M}{\pi(16R^2 - 9R^2)} \times 2\pi x dx$$

$$= \frac{2M}{7R^2} x dx$$

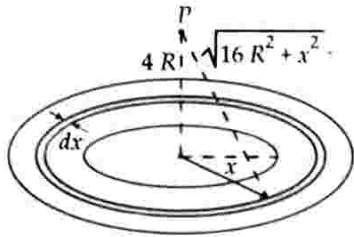

Gravitational potential due to the disc at the point P ,

$$V_P = \int_{3R}^{4R} \frac{-GdM}{\sqrt{16R^2 + x^2}}$$

$$= -\frac{GM}{7R^2} \int_{3R}^{4R} \frac{2x dx}{\sqrt{16R^2 + x^2}}$$

$$= -\frac{GM}{7R^2} \left[\frac{\sqrt{16R^2 + x^2}}{1/2} \right]_{3R}^{4R}$$

$$= -\frac{2GM}{7R^2} (4\sqrt{2}R - 5R)$$

$$= -\frac{2GM}{7R^2} (4\sqrt{2} - 5)$$

Work done in moving a unit mass from P to ∞ ,

$$W = V_\infty - V_P = 0 - \left(-\frac{2GM}{7R} (4\sqrt{2} - 5) \right)$$

$$= \frac{2GM}{7R} (4\sqrt{2} - 5)$$

12. (b) $v_e = \sqrt{2}V$

K.E. of the object at the time of ejection,

$$\text{K.E.} = \frac{1}{2}mv_e^2 = \frac{1}{2}m(\sqrt{2}V)^2 = mV^2$$

13. (b) For motion of a planet in a circular orbit,

Gravitational force = Centripetal force

$$\frac{GMm}{R^{5/2}} = mR\omega^2 = mR\left(\frac{2\pi}{T}\right)^2$$

or $T^2 = \frac{4\pi^2}{GM} \cdot R^{7/2}$

$\therefore T^2 \propto R^{7/2}$

14. (a), (c), (d) The gravitational field is zero at the centre of a solid sphere. The small spheres removed

from the big sphere can be considered as negative masses m each located at A and B . The gravitational fields due to these masses at O will be equal and opposite. Thus the resultant force on a mass at O will be zero. Hence option (a) is correct.

Option (b) is wrong in view of the above discussion.

Now, $y^2 + z^2 = 36$

represents a circle of radius 6 units with centre $(0, 0, 0)$ and the plane of the circle is perpendicular to x -axis. For points outside the sphere, the mass of the sphere can be assumed to be concentrated at the centre. All points of the given circle are equidistant from O , so gravitational potential is same at all points of this circle. Hence option (c) is correct.

The above logic also holds for the circle $y^2 + z^2 = 4$ which just touches the sphere. Hence option (d) is also correct.

15. (a), (b) For $r > R$, the gravitational field due to a sphere of radius R ,

$$F = \frac{GM}{r^2} \quad \text{i.e., } F \propto \frac{1}{r^2}$$

$$\therefore \frac{F_1}{F_2} = \frac{r_2^2}{r_1^2}$$

Hence option (b) is correct.

For $r < R$, the gravitational field is

$$F = \frac{GM}{R^3} \times r \quad \text{i.e., } F \propto r$$

$$\therefore \frac{F_1}{F_2} = \frac{r_1}{r_2}$$

Hence option (a) is correct.

16. (a), (c) Force on a satellite acts towards the earth, so the acceleration of the satellite S is always directed towards the centre of the earth. Hence option (a) is correct.

Net torque due to the gravitational force about centre of the earth is zero. So angular momentum of S remains constant. Hence option (b) is incorrect.

As the gravitational force is conservative in nature, total mechanical energy of S remains constant. Speed of S is maximum when it is nearest to earth and minimum when it is farthest. Thus the mechanical energy of S varies periodically with time. Hence option (c) is correct.

As the magnitude of velocity of S varies along the elliptical orbit, the linear momentum of S does not remain constant in magnitude. Hence option (d) is incorrect.

17. (a) Both statements are correct and statement - 2 is a correct explanation of statement - 1.

18. $a(p, t)$; $b(q, s, t)$; $c(p, r, t)$; $d(q)$

(p) As block Y moves with a constant velocity, force exerted by X may will balance its weight Mg ($p \rightarrow a$).

Work is done against the force of friction, mechanical energy of the system decreases ($p \rightarrow c$).

(q) As lift is moving upwards, the gravitational P.E. of X is continuously increasing ($q \rightarrow b$).

Line of action of Y passes through P , hence torque is zero ($q \rightarrow d$).

(r) As the system $X+Y$ comes down with a constant velocity, its P.E. is decreasing but kinetic energy is constant and hence mechanical energy is continuously decreasing ($r \rightarrow c$).

(s) As the sphere Y moves down, the centre of mass of liquid X rises up, the gravitational P.E. of X increases ($s \rightarrow b$).

(t) As the sphere Y moves down with a constant velocity, the force exerted by the liquid X will balance its weight Mg ($t \rightarrow a$). The gravitational P.E. of liquid X rises due to rise of its CM ($t \rightarrow b$). The mechanical energy of the system $X+Y$ decreases as work is done against viscous force ($t \rightarrow c$).

19.

0	0	0	3
---	---	---	---

$$g_p = \frac{GM_p}{R_p^2} = \frac{4}{3} G\pi R_p \rho_p$$

$$\Rightarrow \frac{g_p}{g_e} = \frac{R_p \rho_p}{R_e \rho_e}$$

$$\text{Also, } v_e = \sqrt{2gR}$$

$$\Rightarrow \frac{v_p}{v_e} = \sqrt{\frac{g_p R_p}{g_e R_e}} = \left(\frac{g_p}{g_e}\right) \sqrt{\frac{\rho_e}{\rho_p}} = \frac{\sqrt{6}}{11} \times \sqrt{3}$$

$$\Rightarrow v_p = 3 \text{ km/s}$$